

Installation Manual - Multi Head Stand

EN Operation manual

3-34



Contents

1 Safety.....	4		
1.1 Safety definitions.....	4		
1.2 General safety instructions.....	4		
1.3 Safety instructions for installation.....	4		
1.4 Safety instructions for the lifting equipment.....	5		
2 Installation.....	6		
2.1 Introduction.....	6		
2.2 To assemble the floor stand.....	7		
2.3 To attach the product to the floor stand..	15		
2.4 To assemble and attach the lifting equipment on a Multi-head group (optional).....	19		
2.5 Transport Lock.....	23		
2.6 Network Setup.....	24		
2.6.1 To connect a Coloreel ITCU to a network.....	24		
		2.6.2 To connect a Coloreel ITCU to a local network.....	25
		2.7 To use the Priming Function.....	26
		2.8 Auto Calibration.....	26
		2.8.1 To do an auto calibration.....	27
		2.8.2 To do a Nozzle check.....	27
		2.8.3 To do a Head Angle Calibration...	28
		2.8.4 To do a Head Position Calibration.....	30
		2.8.5 To do a Head Placement Calibration.....	31
		2.8.6 To get the calibration report.....	32
		2.9 Stitch count settings.....	32
		2.9.1 To manage the CCP settings.....	32
		2.9.2 To align the stitch count settings..	33

1 Safety

1.1 Safety definitions

Warnings, cautions and notes are used to point out especially important parts of the manual.



Warning: Used if there is a risk of injury or death for the operator or bystanders if the instructions in the manual are not followed correctly.



Caution: Used if there is a risk of damage to the product, other materials or the adjacent area if the instructions in the manual are not followed correctly.



Note: Used to give additional information necessary for basic use of the product.

1.2 General safety instructions



Warning: Always read the warning instructions that follow before using the product.

- Read and understand the Operator's Manual, Installation manual and all the instructions on the product carefully before use.
- Do not install, operate or do service and maintenance if you do not fully understand the instructions or how to use the provided parts and products.
- The product creates an electromagnetic field during operation. This field may under some circumstances interfere with active or passive medical implants. To reduce the risk of serious or fatal injury we recommend people with medical implants to consult their physician and the medical implant manufacturer before operating this product.
- The product is approved only with the equipment supplied or recommended by the manufacturer. Failure to use approved equipment can cause damage to the product.
- Electrical shocks can cause injuries. Do not touch the cables when the product is turned on.
- Always follow the instructions provided on the touchscreen.

1.3 Safety instructions for installation



Warning: The service and installation manual shall fulfil the need for installation and service technicians. The receiver of the manual is required to have special training.



Warning: Read the warning instructions that follow before you install the floor stand and the Coloreel unit.

- Always be a minimum of 3 persons during installation. Risk of personal injury.
- The installation procedure described in this manual is recommended by Coloreel for safe operation of the Coloreel unit. Do not install the floor stand or the Coloreel unit in any other way.
- Risk of personal injury. The floor stand can tilt before it is correctly attached to the floor.
- Regularly make sure that the floor stand is stable and correctly attached to the floor. Make sure that the Coloreel unit is correctly installed to the floor stand. Risk of personal injury or death to the operator.

- High humidity can decrease the lifetime of the floor stand and the Coloreel unit. Perform maintenance and inspections regularly.
- Make sure that the Multi-head stand is attached secure and correctly to the floor with the correct locking force.

1.4 Safety instructions for the lifting equipment



Warning: Before attempting to assemble the Lifting Equipment or using the Lifting Equipment to install the Coloreel ITC Unit ("the ITCU"), carefully read, fully understand and follow each of the below Safety Instructions; failing to do so could result in Death or Serious Injury to you or a bystander.

- Use only the included parts and fasteners to assemble the Lifting Equipment and attach it to the multihead rails/stand or single head stand.
- Before each use, make sure that the Lifting Equipment is not damaged and that it is attached correctly. Do not use a wire that is damaged or if the layer of plastic on the wire is damaged. Replace the wire if it is damaged.
- Using the Lifting Equipment may require you to work at heights. If you are required to work at heights when installing the ITCU, make sure that you select and use climbing equipment appropriate for the height at which you will be working and for any weight the climbing equipment must support, including your weight and that of your tools. Carefully read, fully understand and follow all instructions provided with the climbing equipment.
- Only use the Lifting Equipment to lift the Coloreel ITCU. Do not use the lifting equipment for any other tasks.
- Only use original Coloreel spare parts that are approved by Coloreel.
- Never operate under the Coloreel ITCU while it is being lifted or while it is suspended.
- Make sure that the Coloreel ITCU is secured correctly and that it cannot move or fall down before you operate the Coloreel ITCU.

2 Installation

2.1 Introduction



Warning: Be careful when installing the adjustment beams. Risk of crush injuries.



Caution: Ensure the Coloreel unit is installed at an angle not deviating more than 3° from the horizontal plane.



Caution: The distance between the Coloreel unit and embroidery needle should be as short as possible for best color precision. The length of the thread between the output and the needle should not exceed 100 cm. Adjust the height adjustment beam accordingly. Refer to [2.2](#).



Caution: Install the Coloreel unit so that the angle of the thread between the Coloreel unit and embroidery machine does not deviate more than 10° from the vertical axis.

2.2 To assemble the floor stand

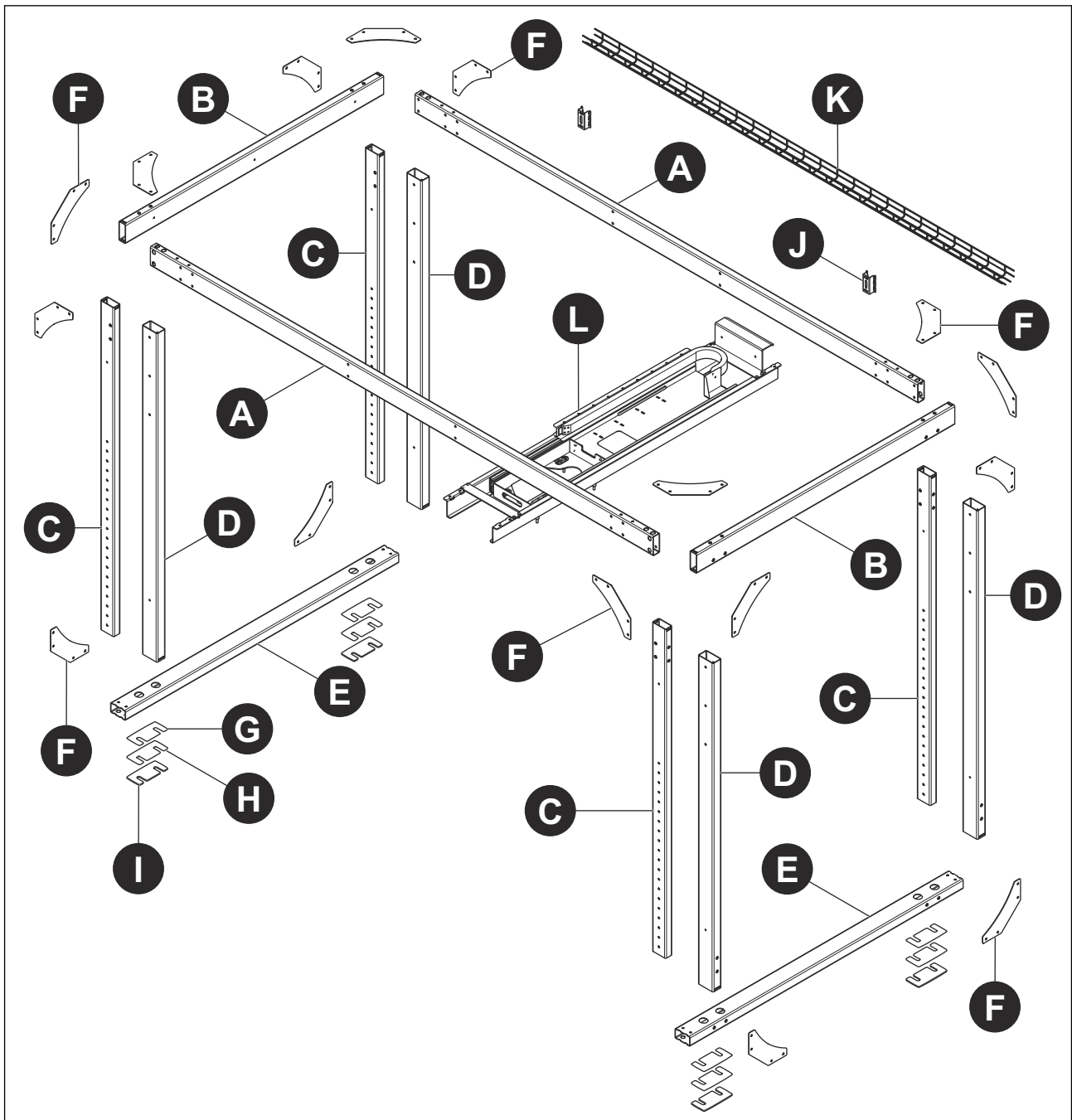

Reference	Amount	Name
A	2	Multihead beam
B	2	Top gable beam
C	4	Inner pillar
D	4	Outer pillar
E	2	Floor beam
F	16	Reinforcement
G	4	Shim, 1 mm

Reference	Amount	Name
H	4	Shim, 3 mm
I	4	Shim, 5 mm
J	2	Brackets for the cable tray
K	1	Cable tray
L	1-8	Multihead rail

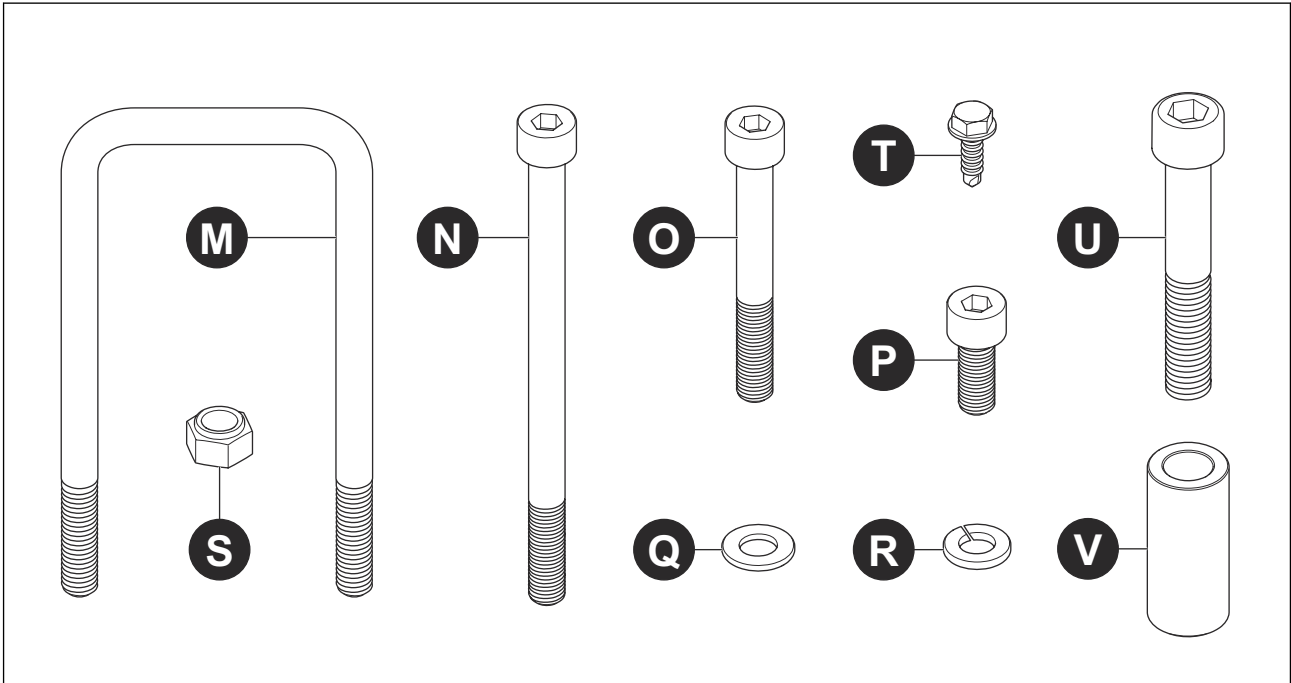

Reference	Amount	Name
M	4	U-Clamp M8
N	8	Bolt, MC6S M8x120
O	20	Bolt, MC6S M8x65
P	72	Bolt, MC6S M8x20
Q	64	Washer, BRB 8,4x16x1,6
R	72	Washer, FBB 8,1x14,8x2
S	36	Nut, M6M M8
T	4	Screw ST 4,8x16
U	4	Bolt, MC6S M10x65
V	4	Distance



Note: The Coloreel unit must be installed in a space with a minimum distance of 260 cm between the floor and the roof.

1. Measure the height of the embroidery machine and the Coloreel unit. Calculate the necessary height of the floor stand.

2. Assemble the right side of the floor stand.

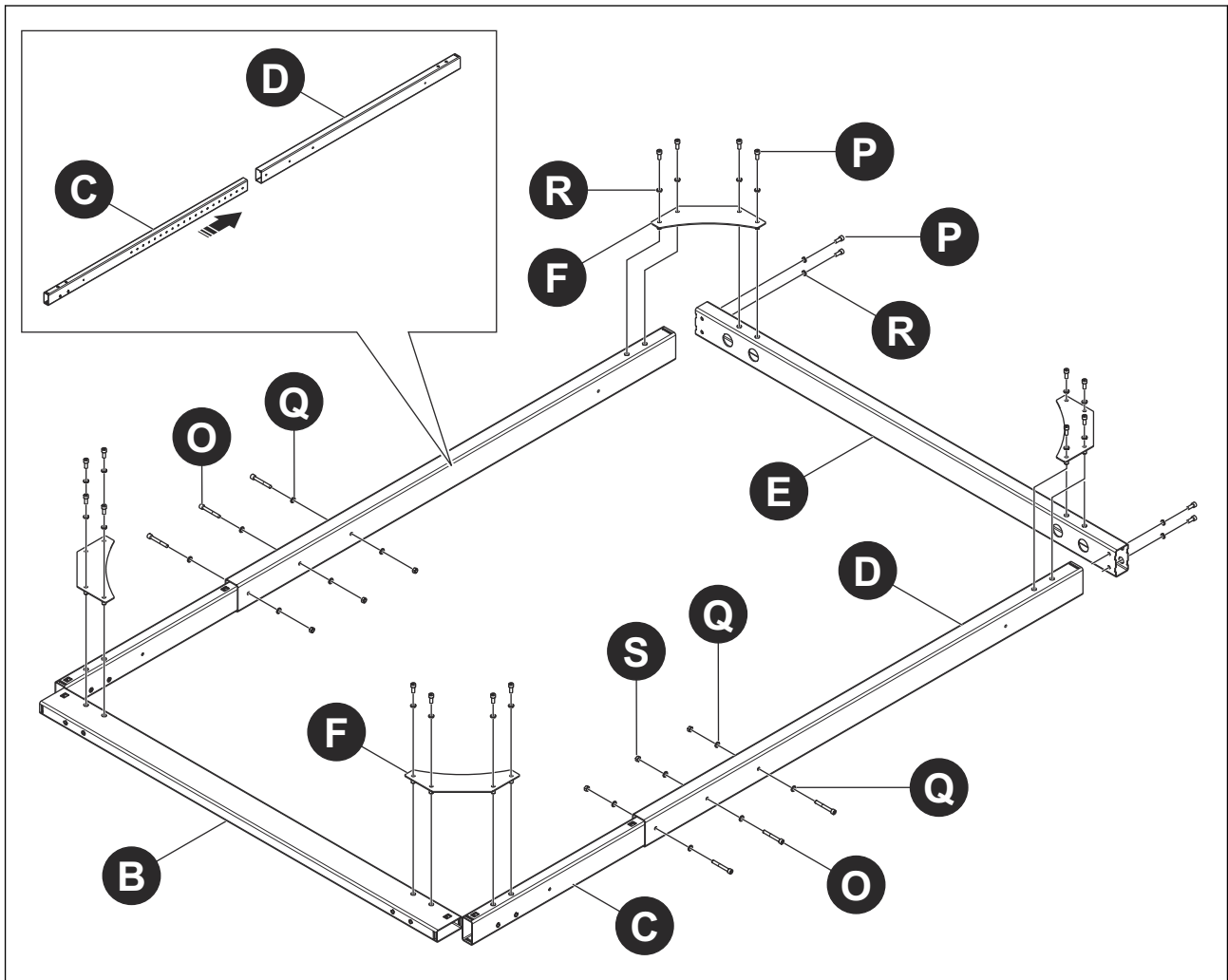

- a. Put the inner pillar (C) in the outer pillar (D). Adjust the height of the pillar to the calculated height of the floor stand. Install the bolts (O), washers (Q) and nuts (S).
- b. Install the pillars (C+D) to the top gabel beam (B) and the floor beam (E) with the washers (R) and bolts (P).
- c. Measure across the section from corner to corner. Adjust the section until the 2 measurements are the same. Tighten the bolts.
- d. Install the reinforcements (F) with the washers (R) and bolts (P).

3. Assemble the rear side of the floor stand.

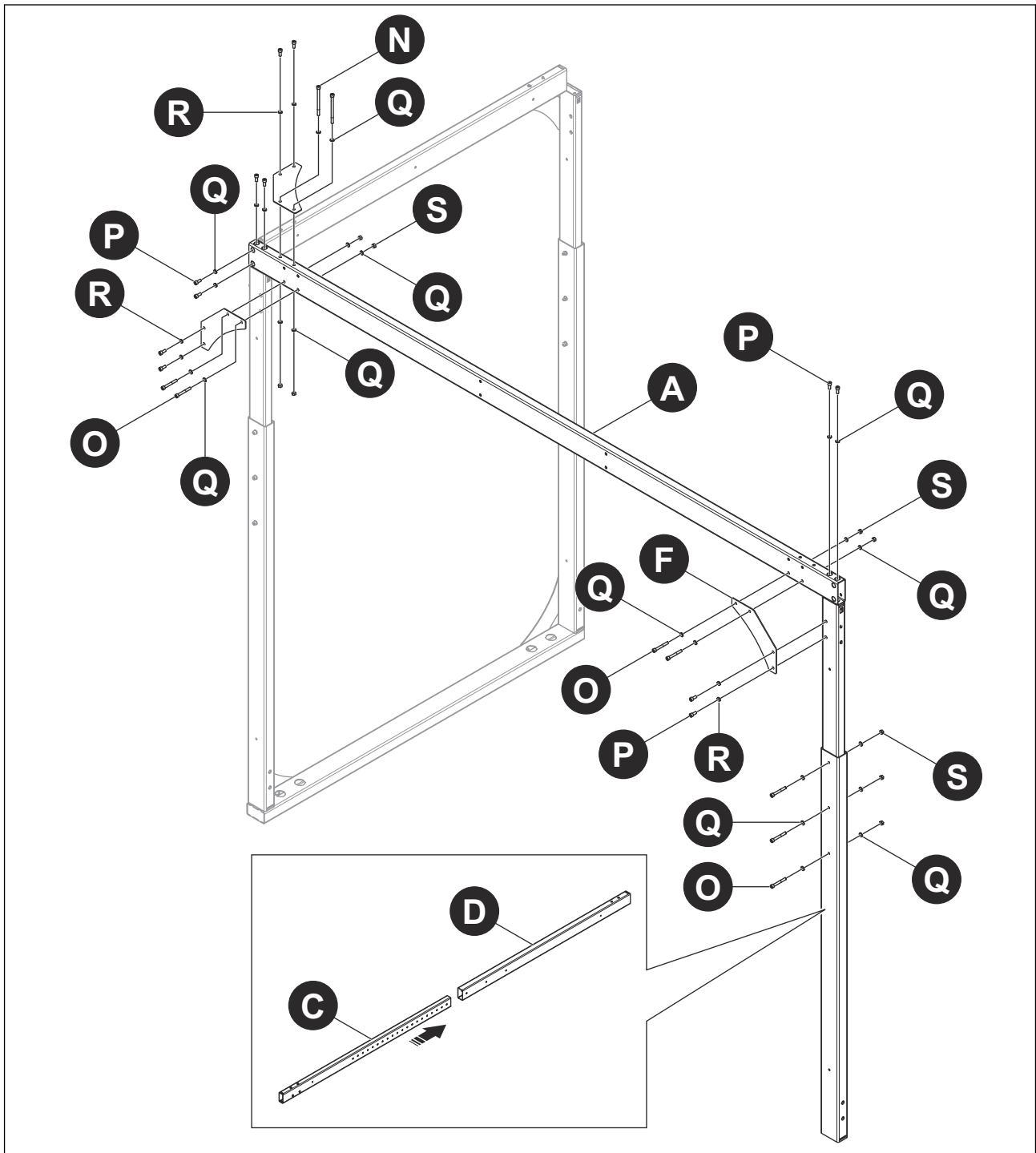

- a. Install the multihead beam (A) with the washers (R) and bolts (P) to the right side assembly and the pillar (C+D).
- b. Measure across the section from corner to corner. Adjust the section until the 2 measurements are the same. Tighten the bolts.
- c. Install the reinforcements (F) with bolts (O)(N), washers (Q) and nuts (S), and the washers (R) and bolts (P).

4. Assemble the left side of the floor stand.

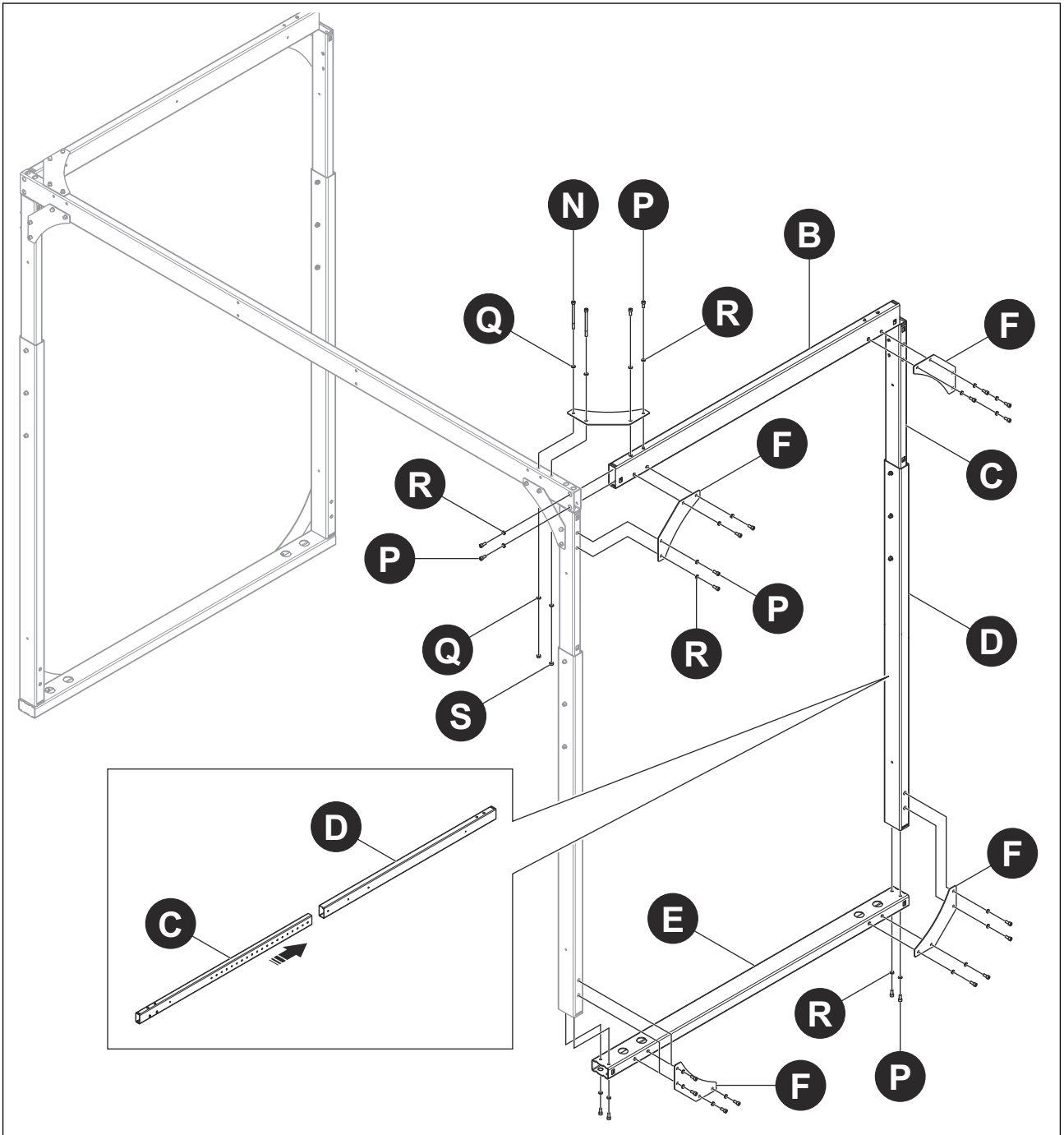

- Install the pillar (C+D) to the top gabel beam (B) and the floor beam (E) with the washers (R) and bolts (P).
- Measure across the section from corner to corner. Adjust the section until the 2 measurements are the same. Tighten the bolts.
- Install the reinforcements (F) with bolts (N), washers (Q) and nuts (S), and the washers (R) and bolts (P).

5. Assemble the front side of the floor stand.

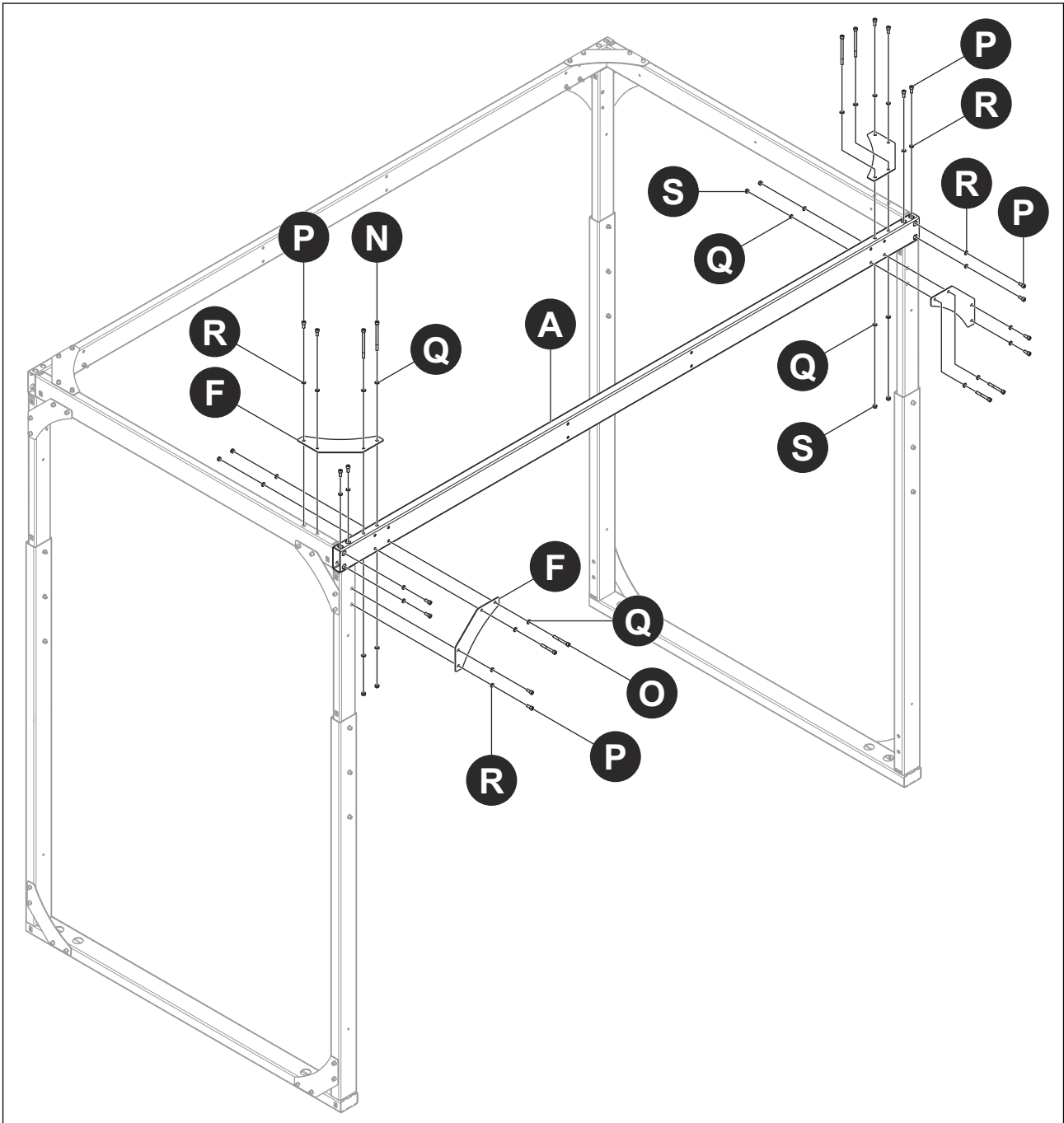

- Install the multihead beam (A) with the washers (R) and bolts (P).
- Measure across the section from corner to corner. Adjust the section until the 2 measurements are the same. Tighten the bolts.
- Install the reinforcements (F) with bolts (O)(N), washers (Q) and nuts (S), and the washers (R) and bolts (P).

6. Install the brackets for the cable tray (J) with the screws (T). Install the cable tray (K).

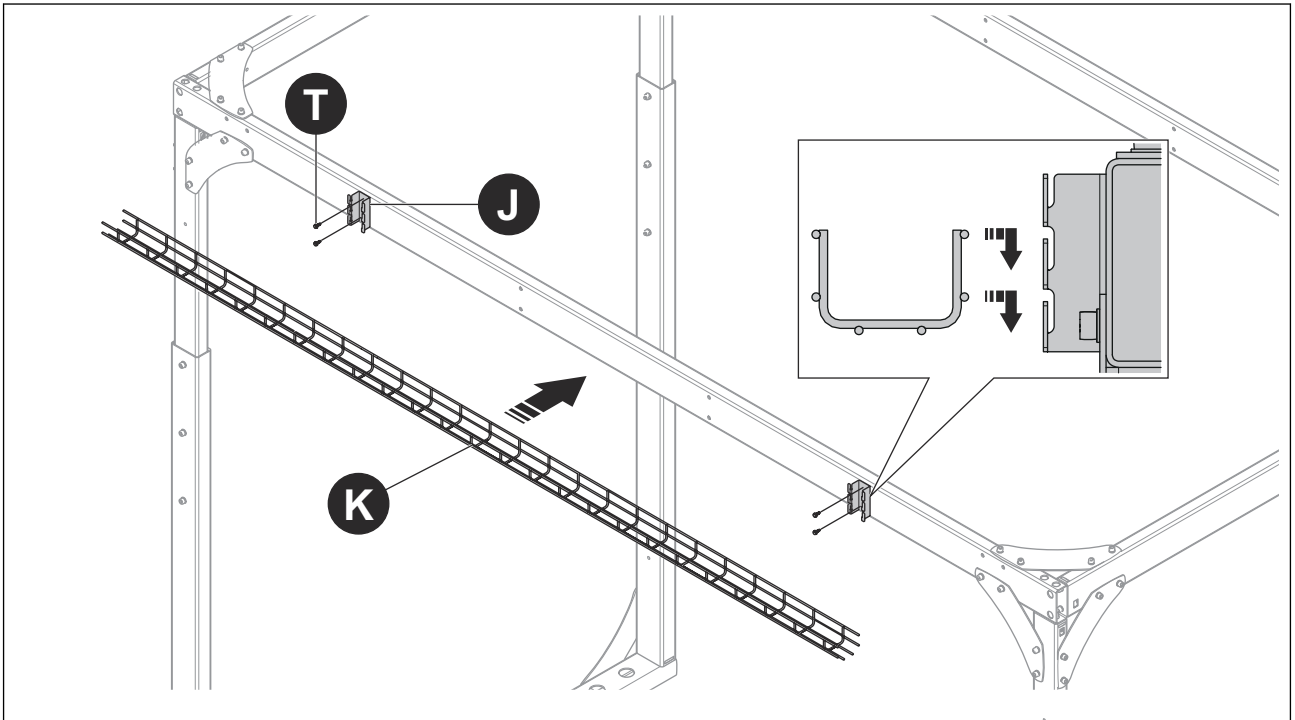

7. Put the floor stand in position. Use the shims (G, H, I) to make the floor stand level. Attach the floor stand to the floor.

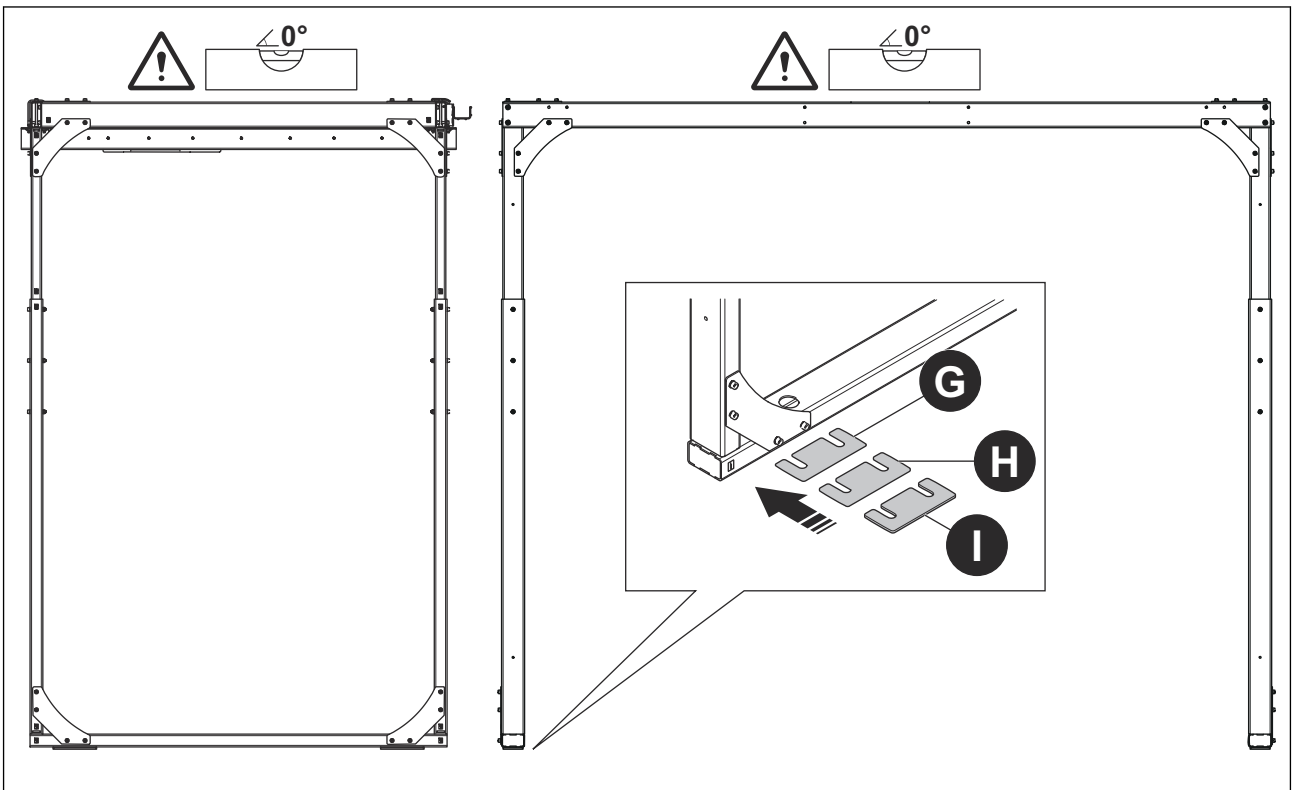

8. Install the multihead rail.

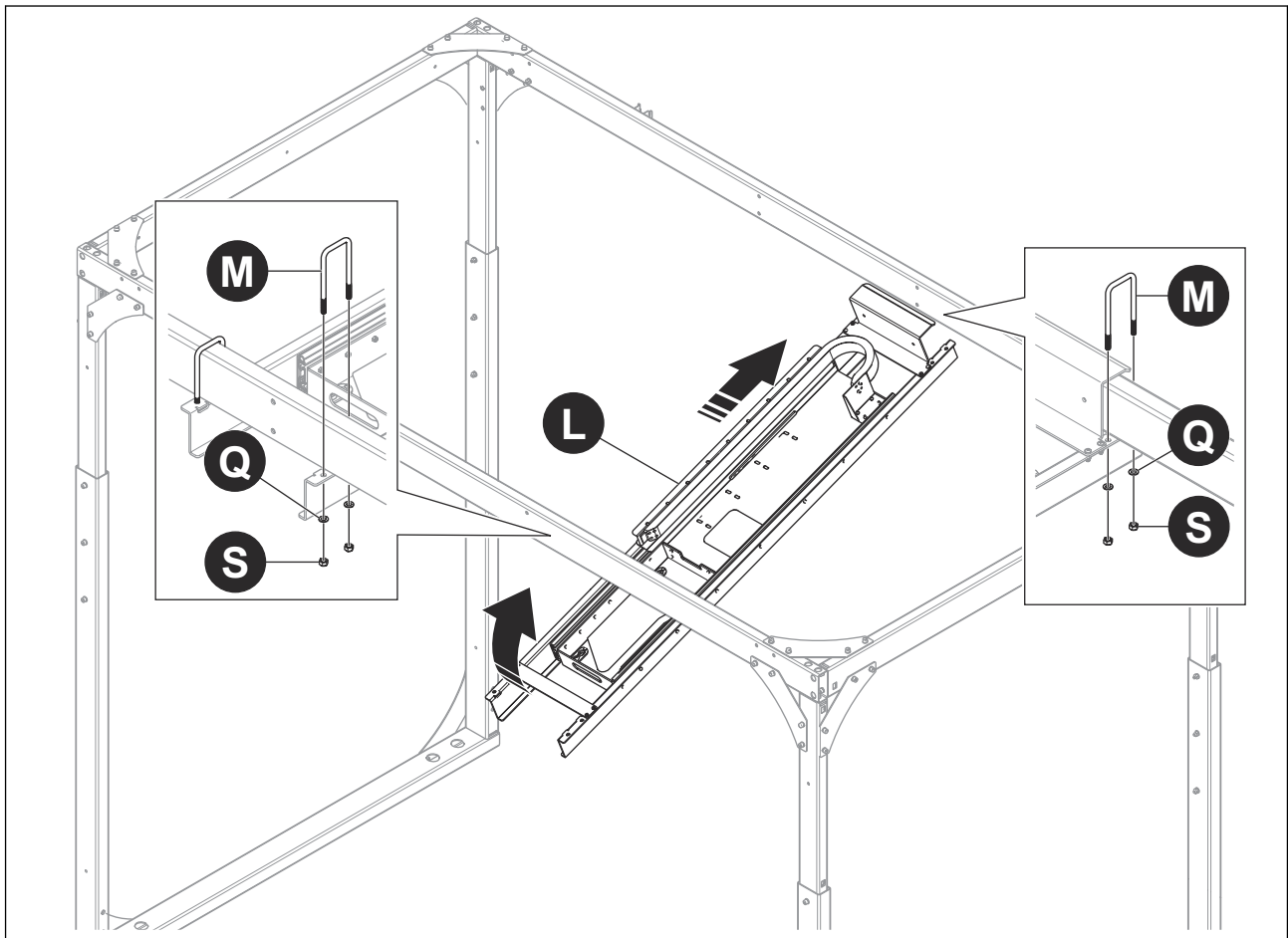

- a. Put the multihead rail in position on the rear multihead beam.
- b. Install the multihead rail on the front multihead beam with the U-shaped brackets (M), washers (Q) and nuts (S).
- c. Install the multihead rail on rear multihead beam with the U-shaped brackets (M), washers (Q) and nuts (S).

2.3 To attach the product to the floor stand

1. Install the bolts (U) and the distances (V) to the frame plate of the Coloreel unit. Tighten the bolts until you have a 10-12 mm clearance between the head of the bolt and the distance.

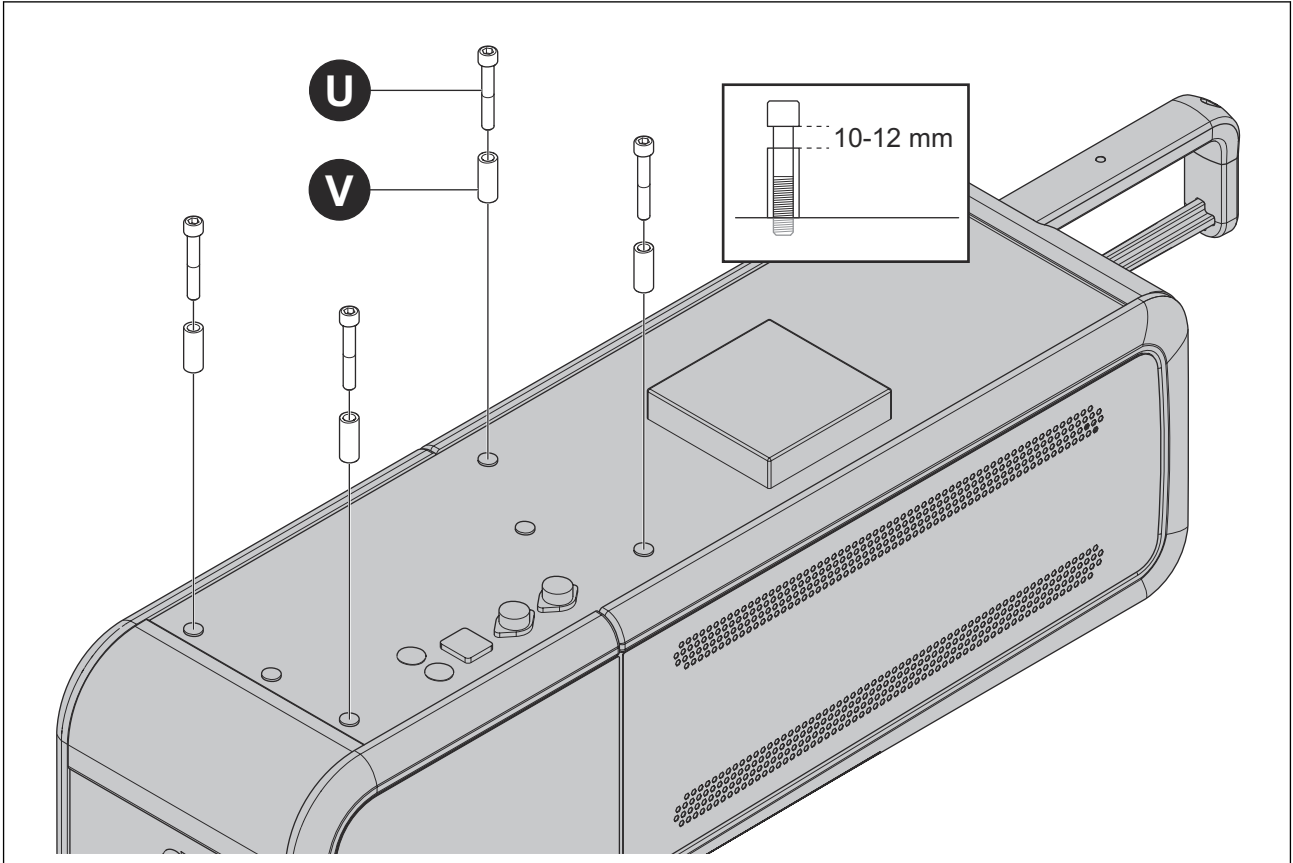

2. If you have the optional lifting equipment, read the instruction in chapter [2.4](#).
3. Remove the detachable doors on the Coloreel unit.

4. Lift up the Coloreel unit and align the bolts with the holes in the multihead rail on the floor stand. Put the bolts into the holes and push the Coloreel unit rearward to lock it to the multihead rail.

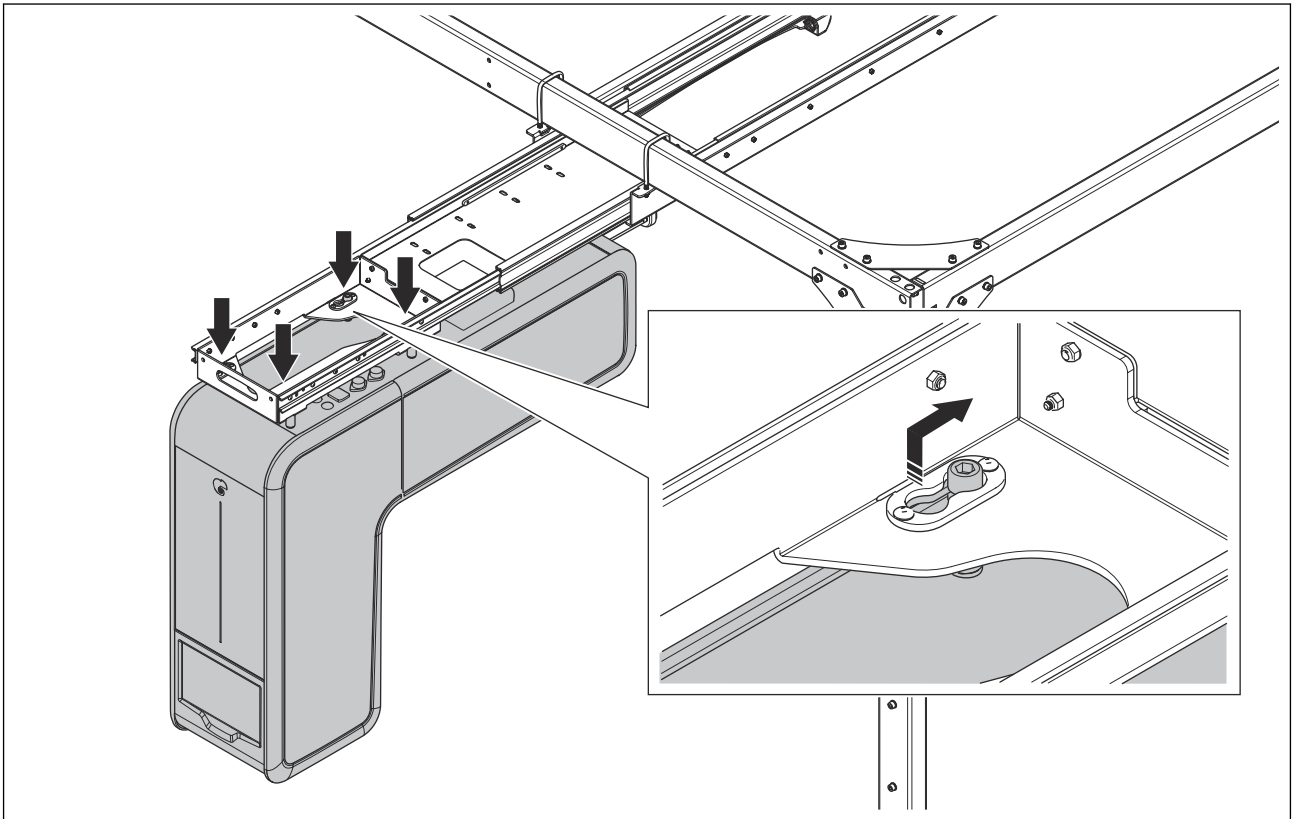

5. Tighten the bolts.

6. Put the cables for the Coloreel unit in position on the multihead rail. Connect the cables to the Coloreel unit. Attach the cables with cable ties.

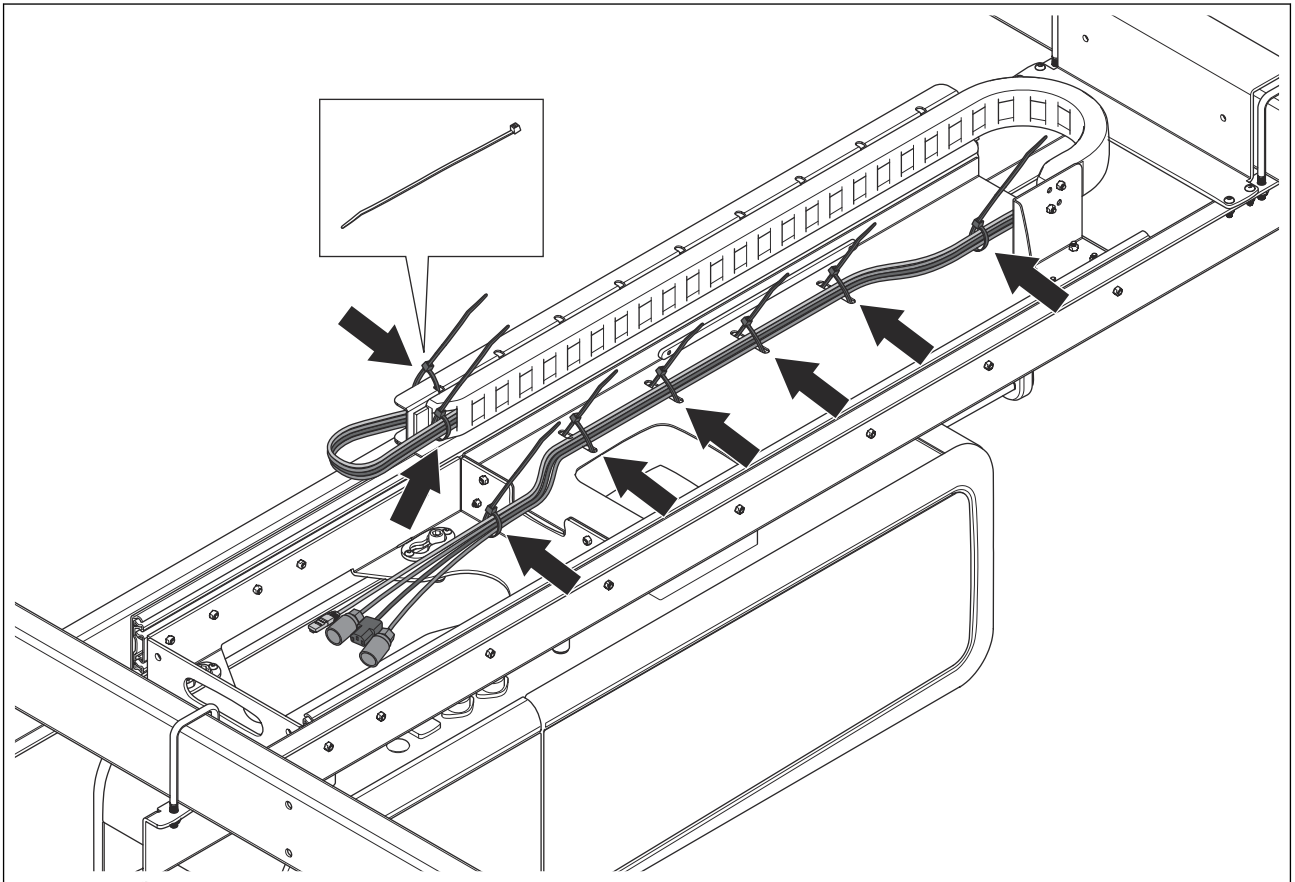

7. Install the detachable doors on the Coloreel unit and assemble the thread reel.

- Put the embroidery machine in place and make sure that the thread is vertically aligned with the inlet of the thread on the embroidery machine. The angle on the thread should not deviate more than 10° from the vertical line (α) of the ITCU thread outlet (C).

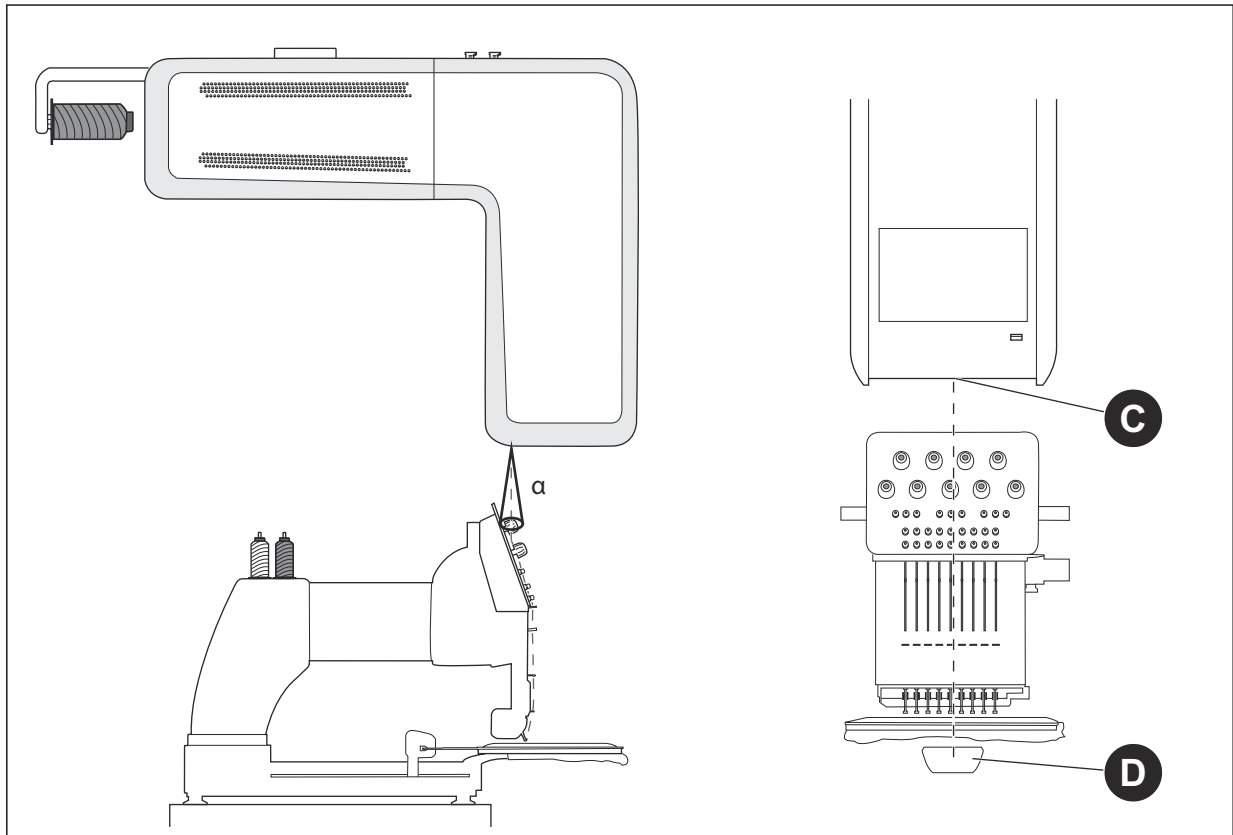

- Make sure that the thread is vertically aligned between the thread outlet (C) and the center of the under thread arm (D).

2.4 To assemble and attach the lifting equipment on a Multi-head group (optional)

1. Pull the multihead rail out. Put the main plate onto the multihead rail. The guide pins on the main plate fits in the holes on the multihead rail. Attach the main plate with 2 knobs.

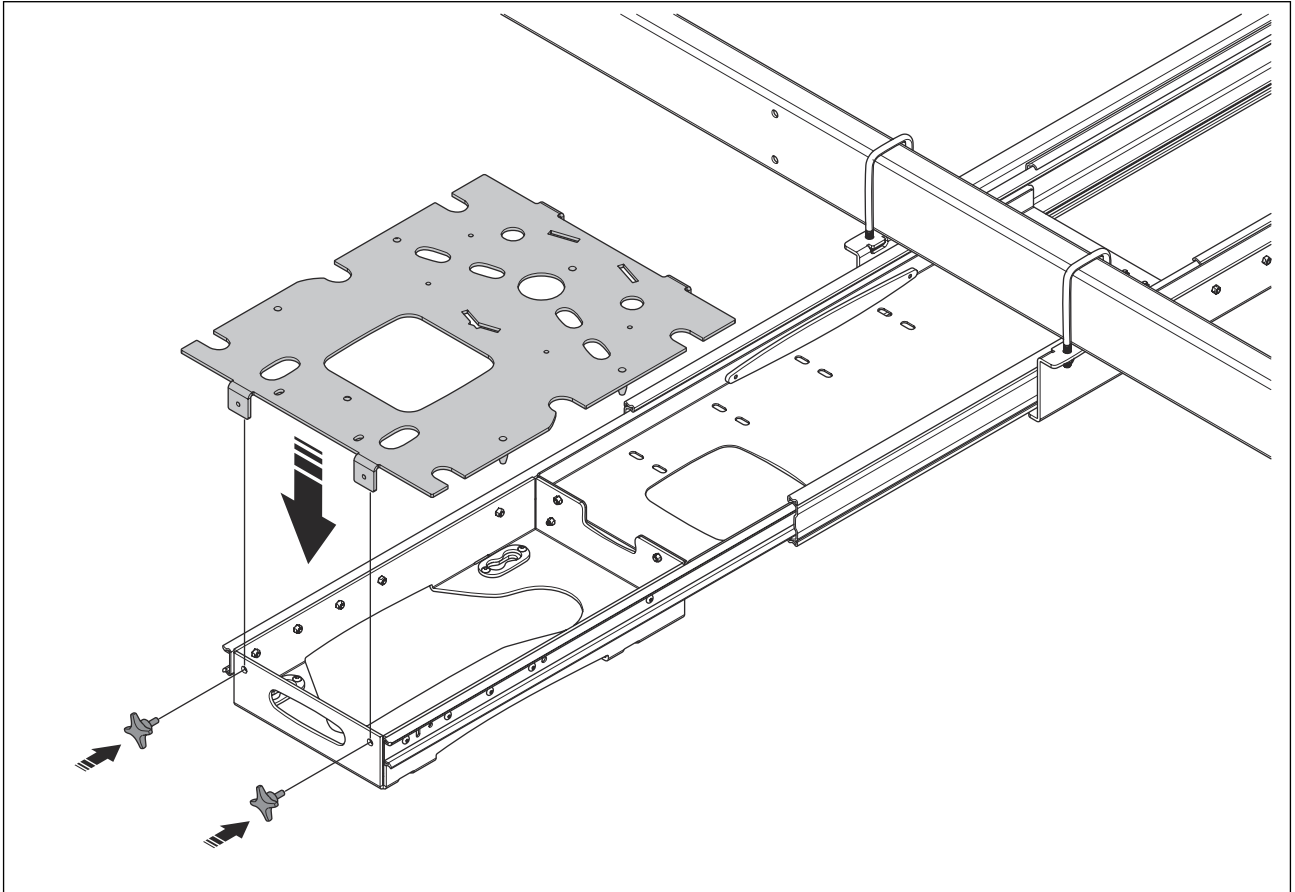

2. Make sure that the main plate is installed correctly as shown in the illustration and tighten the bolts fully.

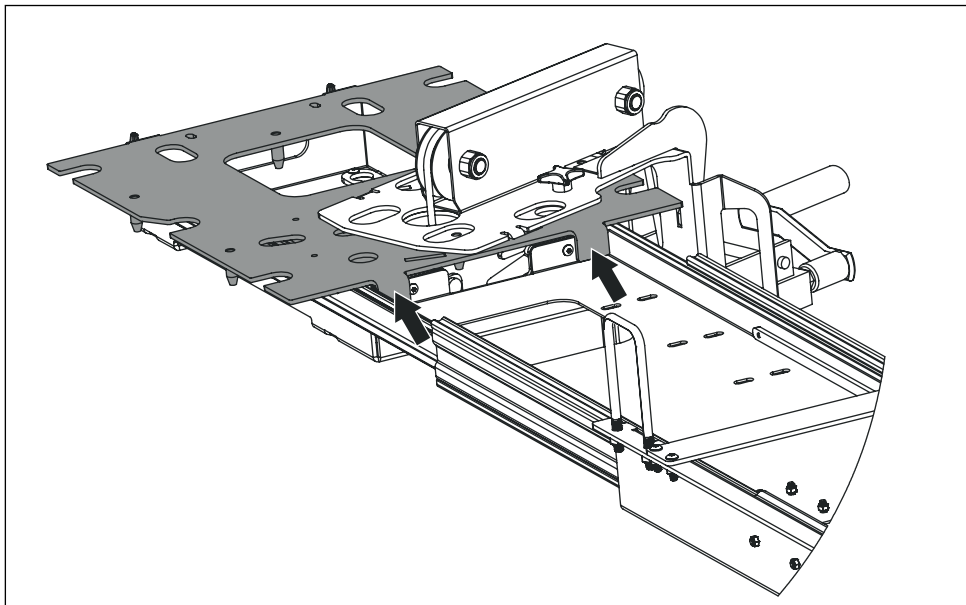

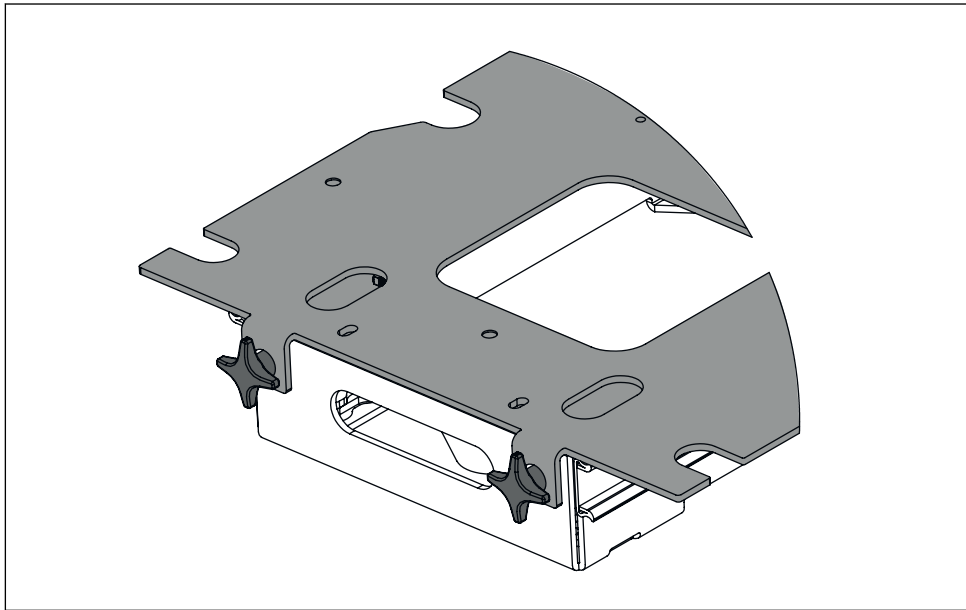

3. Unlock the locking pin. Remove the loop plate from the eyelet on the lifting device.

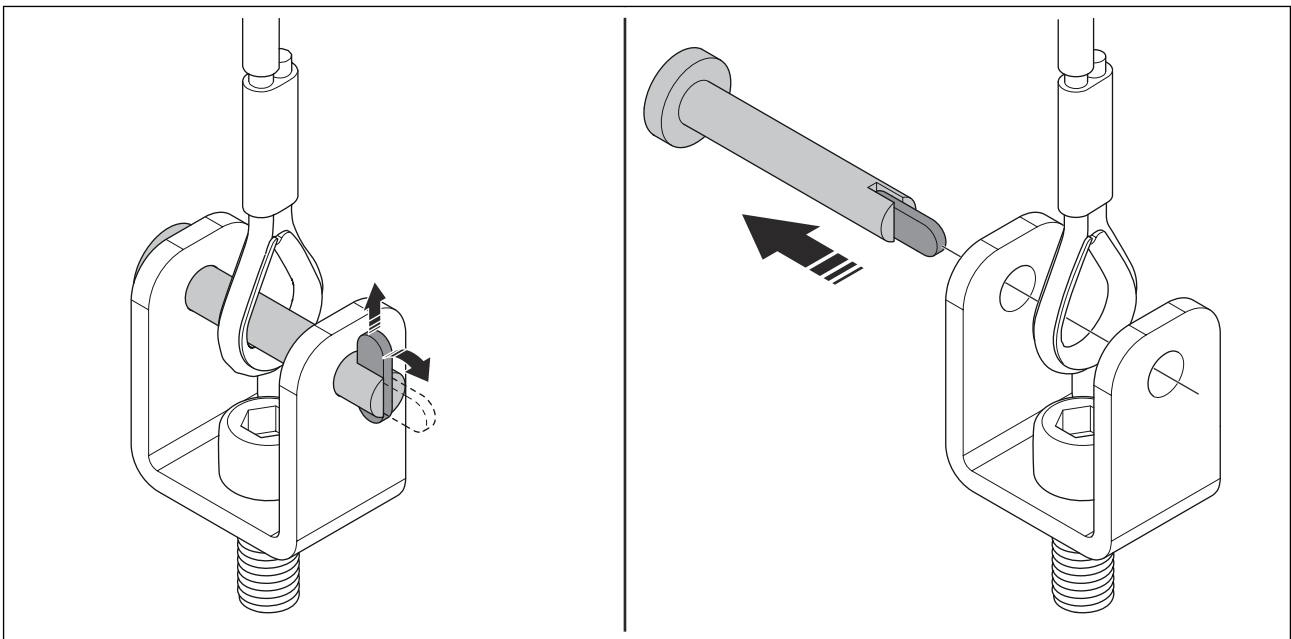

4. Install the loop plate to the Coloreel unit.

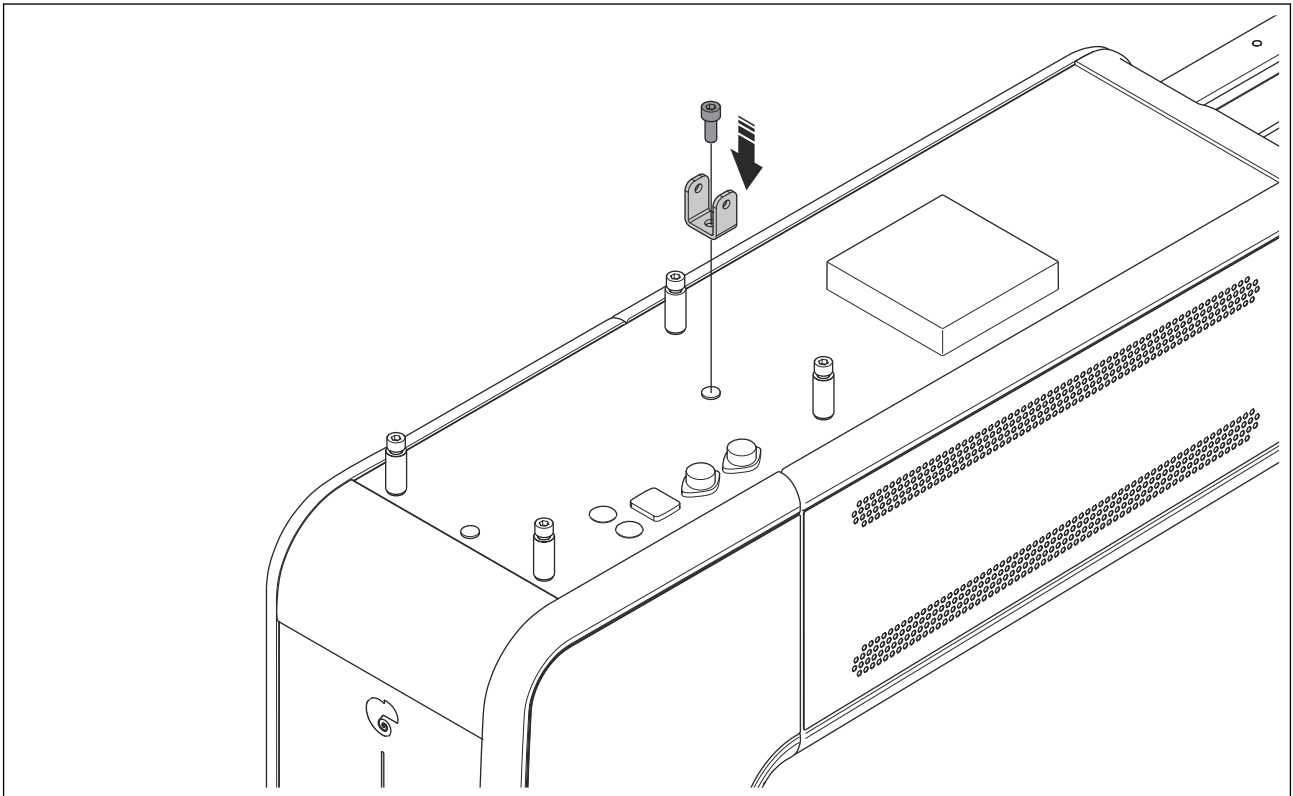

5. Put the lifting device onto the main plate. Attach the lifting device with 2 knobs.



Note: You can attach the lifting device from the left side or the right side on the main plate.

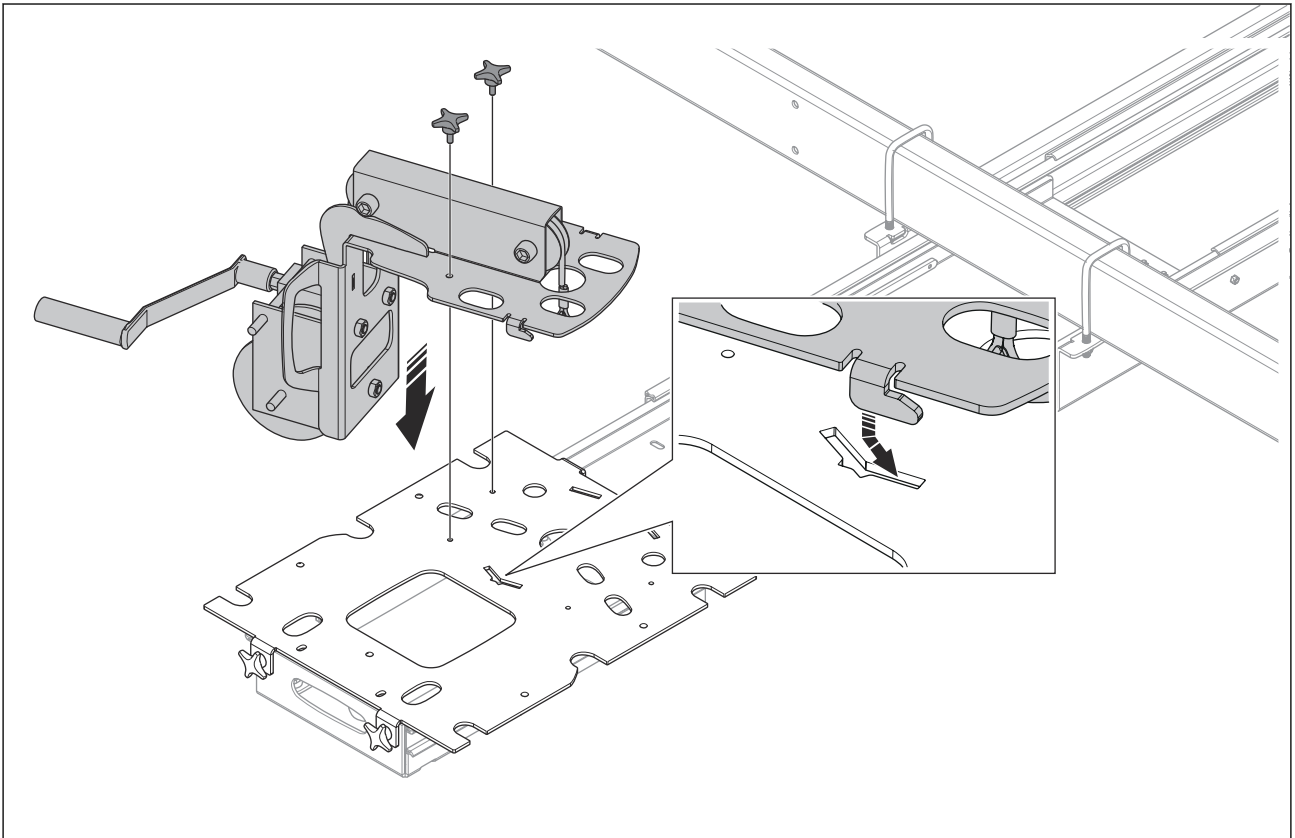

6. Lower the wire.

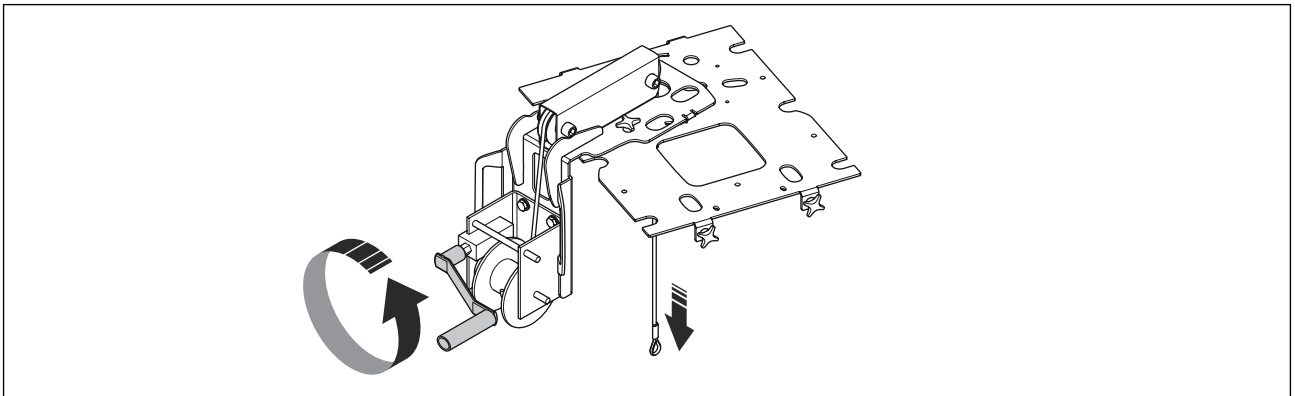

7. Attach the wire eyelet to the loop plate with the locking pin and make sure that the pin is locked.

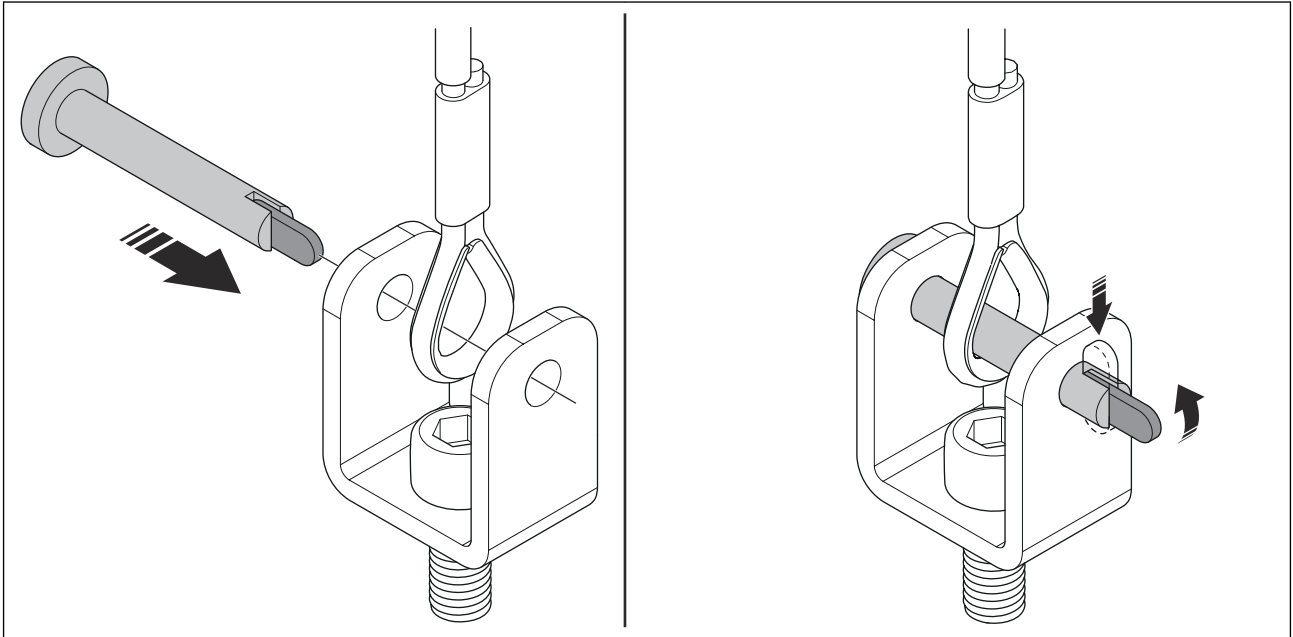

Warning: Make sure to lock the locking pin correctly before you lift the Coloreel unit.



8. Lift up the Coloreel unit and continue to read the instructions in chapter [2.3](#).
9. Remove the lifting equipment in the opposite sequence.

2.5 Transport Lock



Note: Make sure that you remove all the transport locks (A) before you start the ITCU.

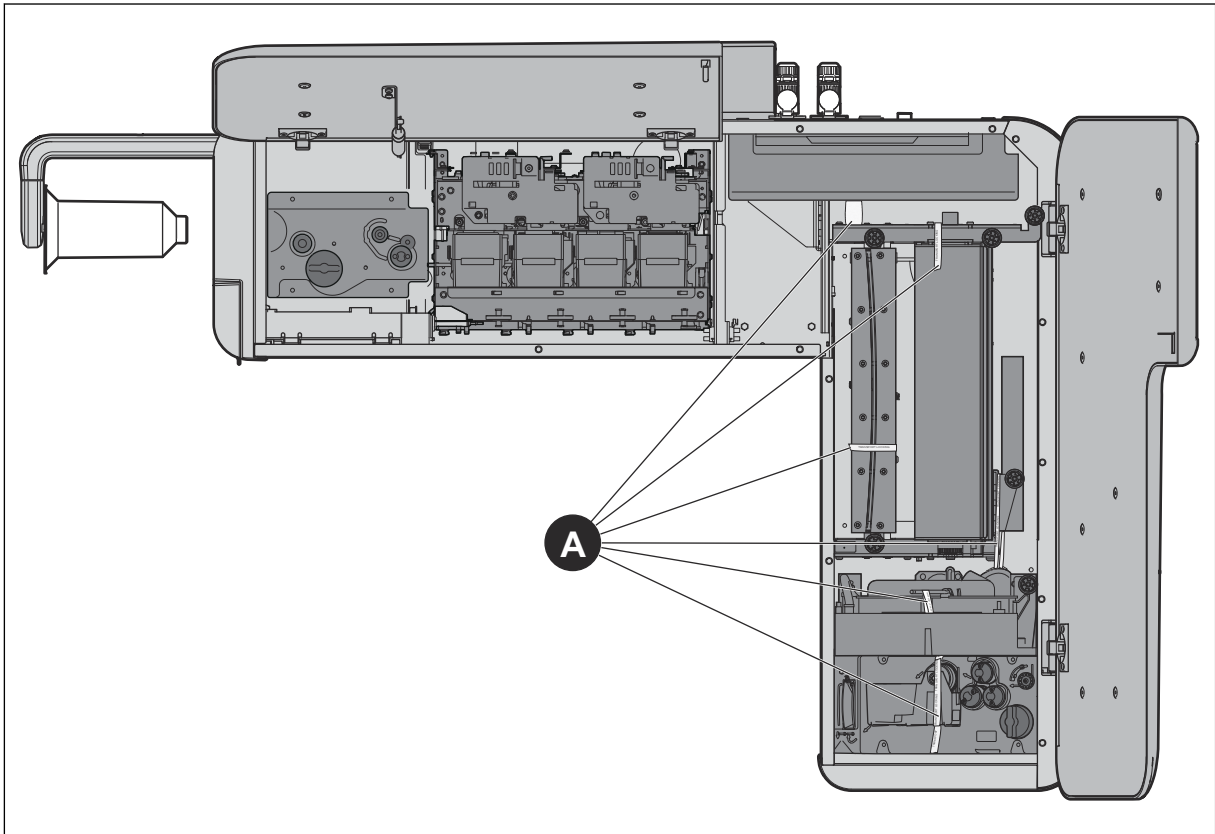

2.6 Network Setup

To use the ITCU, you must install it to a network. We recommend that you install it to an internet connected network to make sure that you get the latest software updates. If that is not possible, you can connect the ITCU through a local network.

2.6.1 To connect a Coloreel ITCU to a network

Make sure that you have a Router (B), access to the internet (C) and a Computer for the Service Tool. The ITCU units will have a separate network inside the company network.

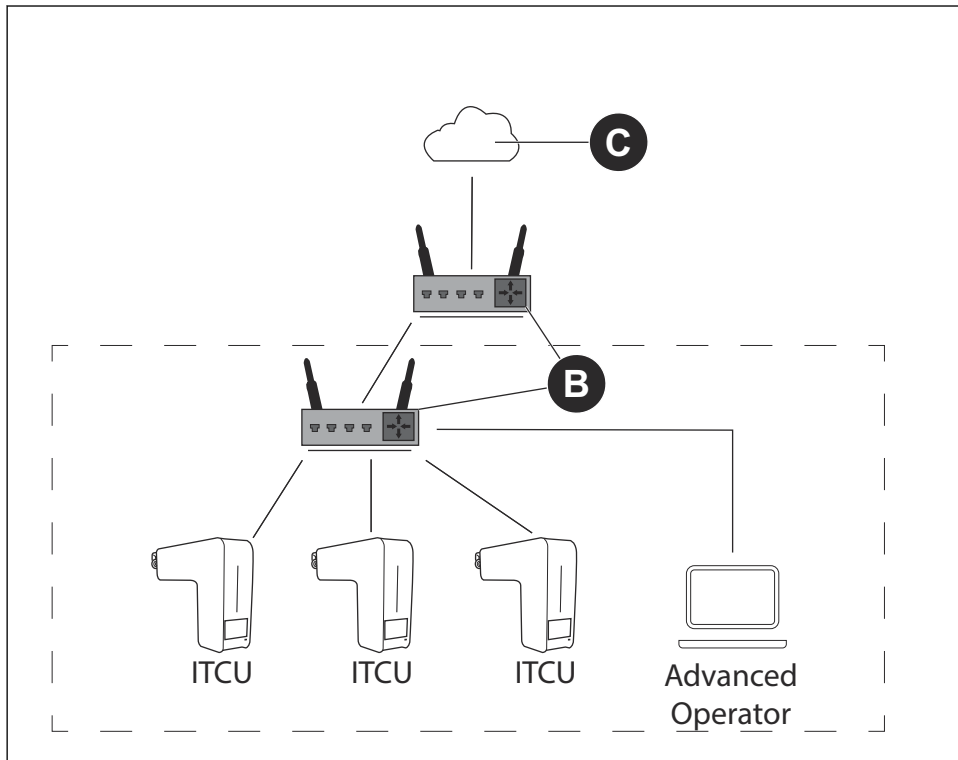

1. Connect the ITCU to the Router (B).
2. Connect the computer to the network with internet access (C).
3. Get the IP address from the ITCU.
4. Log on to the operator panel. You can see the network settings in *Settings>Network*. Refer to the *Full operator manual* for more information.

2.6.2 To connect a Coloreel ITCU to a local network

Make sure that you have a Switch/Router (A) supporting network layer 3 and a Computer for the Advanced Operator access.

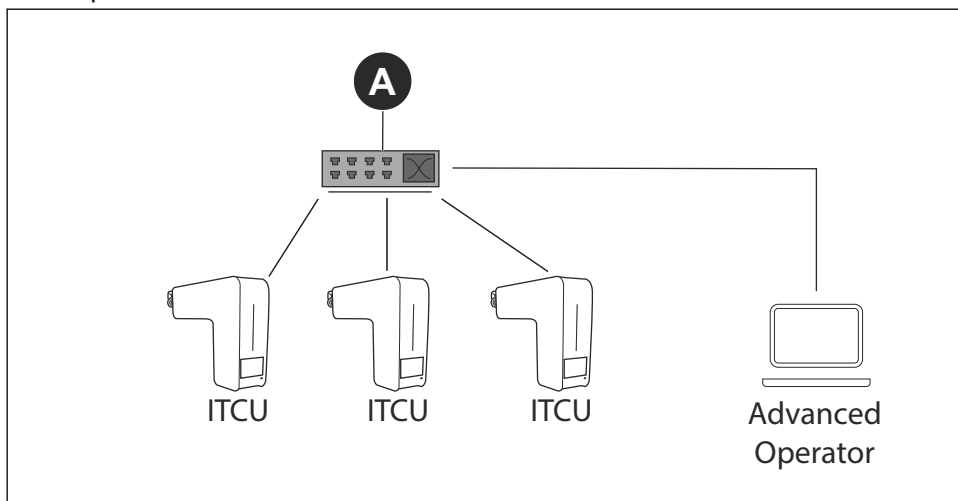

1. Connect the ITCU to the Switch/Router (A).
2. Connect the Computer to the Switch/Router (A).
3. Your Router should use DHCP (ITCU's default configuration) to assign IP Addresses. Get the Coloreel ITCU IP from the screen.
4. Log on to the operator panel. You can see the network settings in *Settings>Network*. Refer to the *Full operator manual* for more information.

2.7 To use the Priming Function

The Priming Function must be used before operating the Coloreel unit for the first time.

1. Ensure that all the color cartridges are installed before starting the Coloreel unit.
2. Make sure that the Waste Tank is empty.
3. In the operator panel, select *Maintenance*.



4. Select *Prime* (A).
5. Click on the *Start prime* button (B).
6. Click in the *Confirm* button (C). The prime procedure starts.

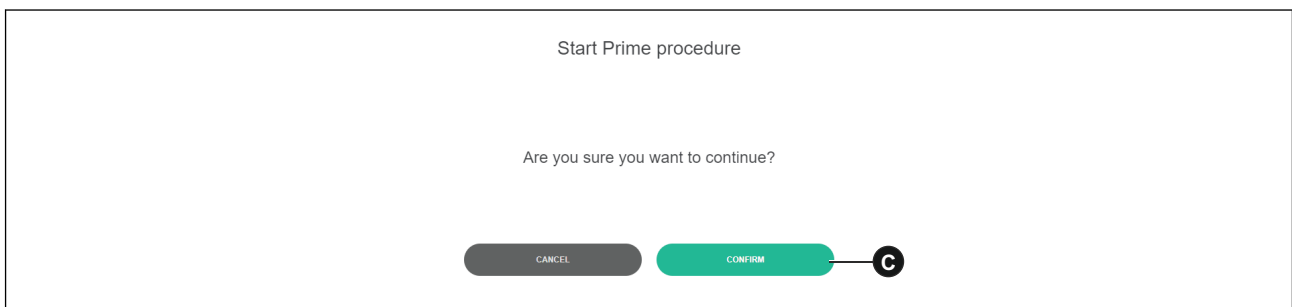

2.8 Auto Calibration

On the Auto Calibration Card (A), it is possible to calibrate print heads so that ink is correctly applied to the thread.

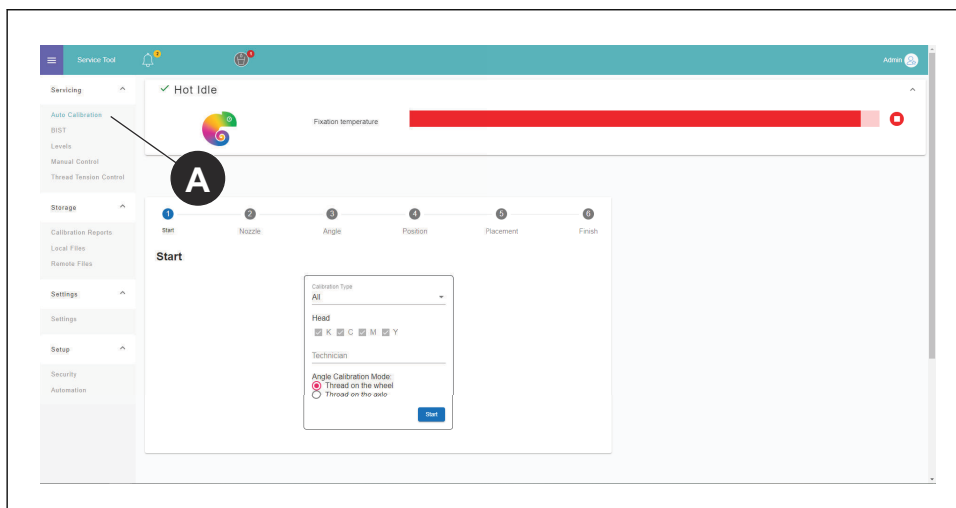

2.8.1 To do an auto calibration

The auto calibration can be done in different ways. The *All* calibration mode will calibrate all colors. Other calibration modes can do calibrations for 1 color separately.

1. Select the calibration mode *All* from the drop down list (B).

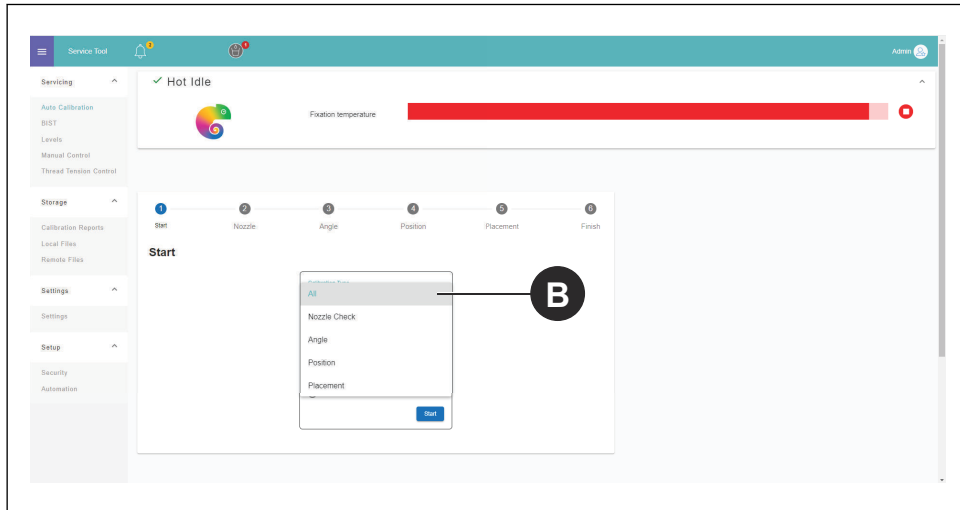

2. Press start and let the auto calibration finish.



Note: The ITCU enters *Service Mode* and warm up, when you start the auto calibration.

2.8.2 To do a Nozzle check

1. Select the calibration mode *Nozzle check* from the drop down list (B).

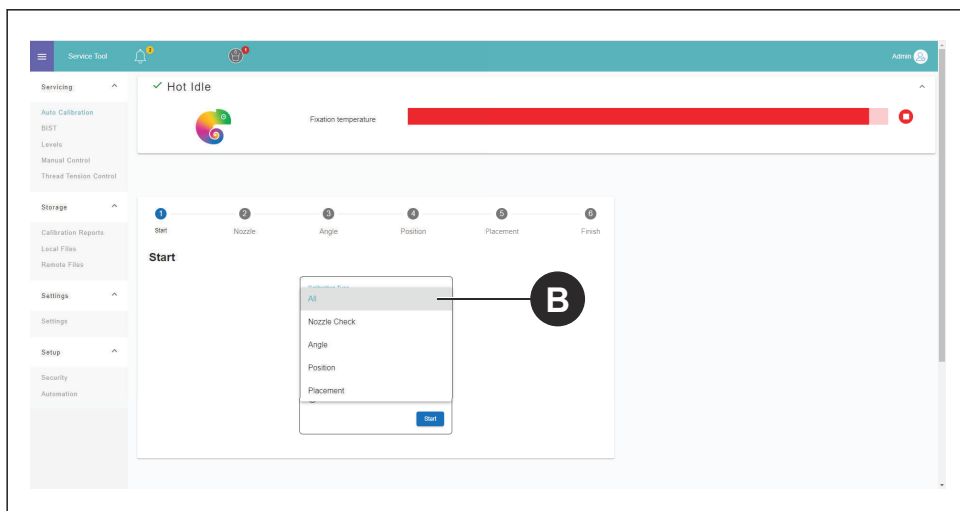

2. Press start.
3. Hold a piece of paper between the thread and the nozzle head.
4. Pull the paper against you and at the same time, pull the thread in the direction of the thread feed.

5. Make sure that there is color on each section.

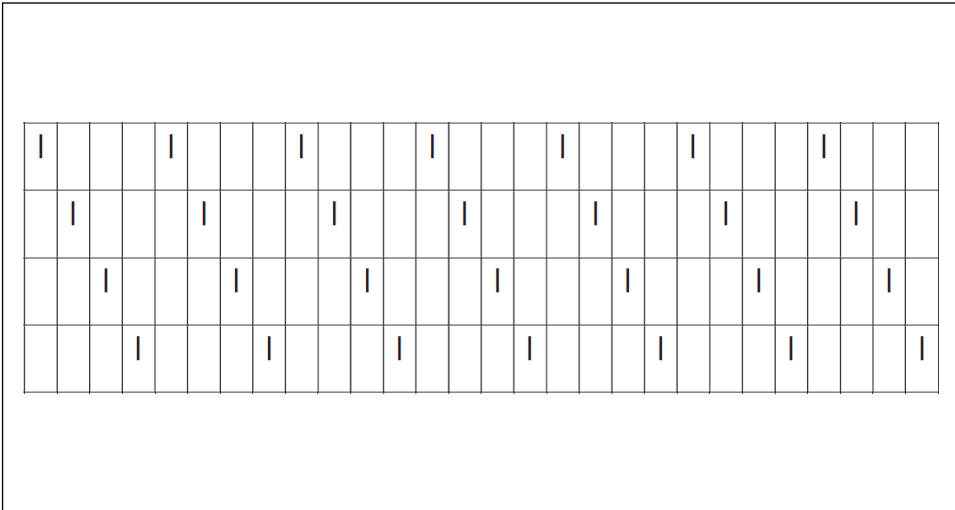

2.8.3 To do a Head Angle Calibration

1. Select the calibration mode *Head Angle Calibration* from the drop down list (B).

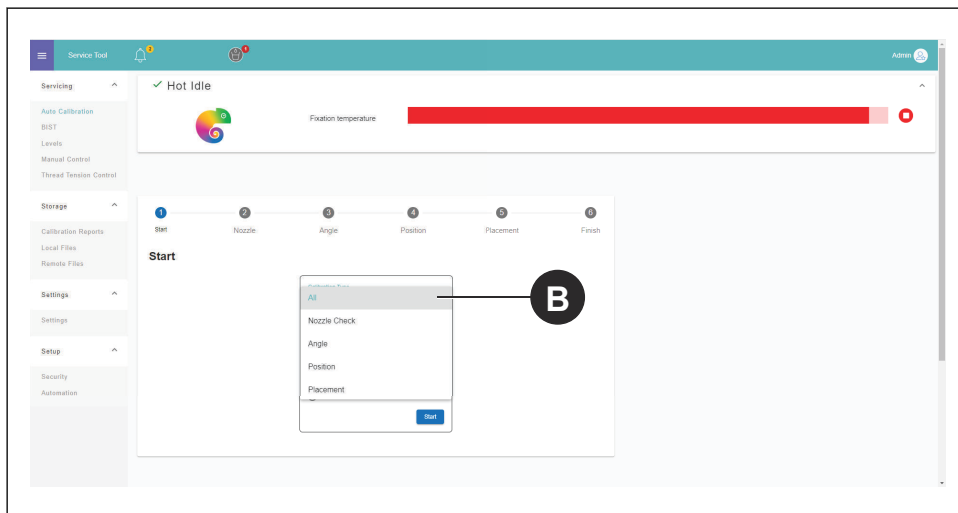

2. Pull the

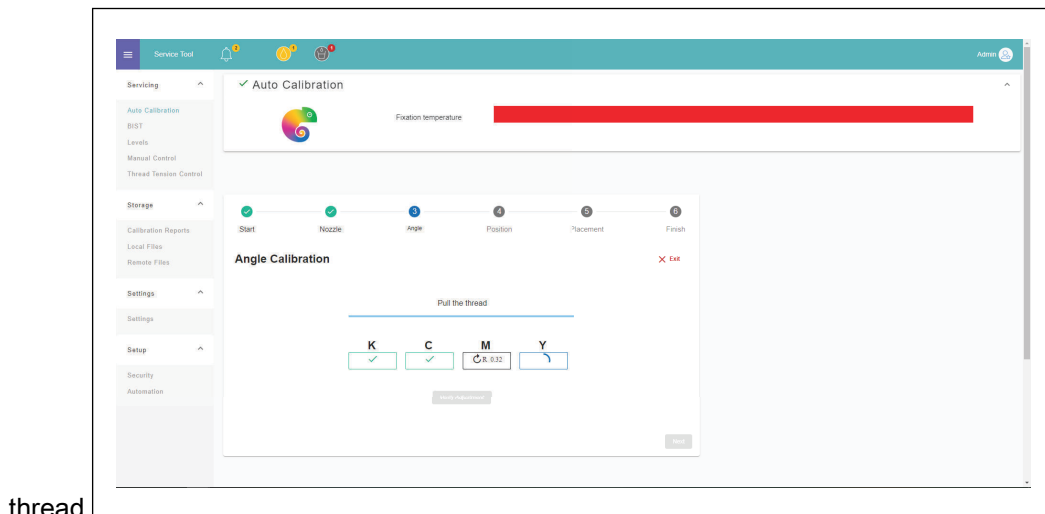

thread.

3. If an adjustment is needed, press *start*

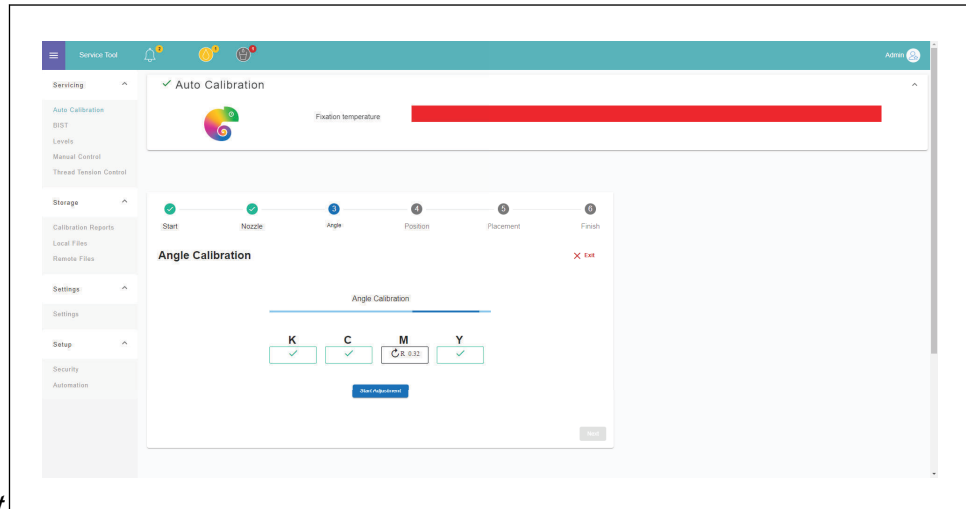

adjustment.

4. Adjust the colors that shows a deviation on the screen.

5. Press *Cap current head* when the adjustments are

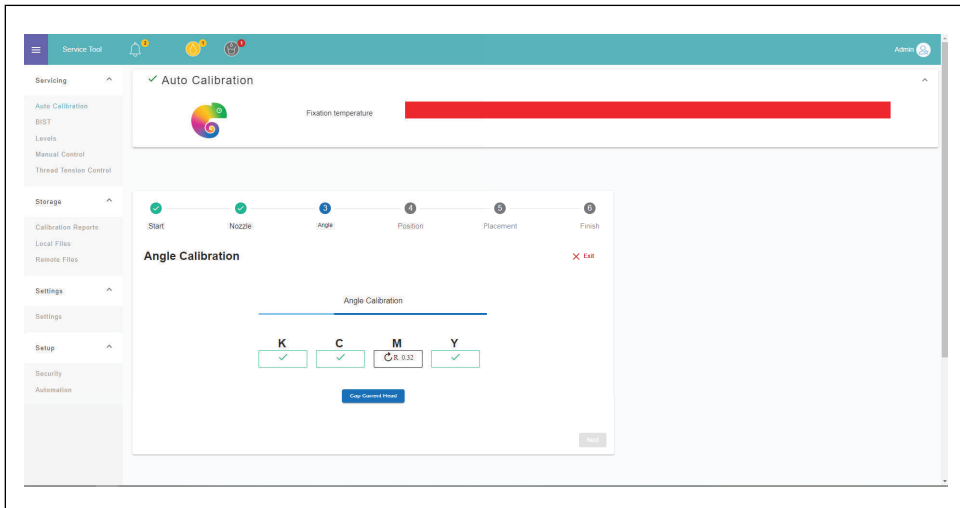

done.

6. Press *verify adjustment* and pull the thread to do a calibration of the adjusted

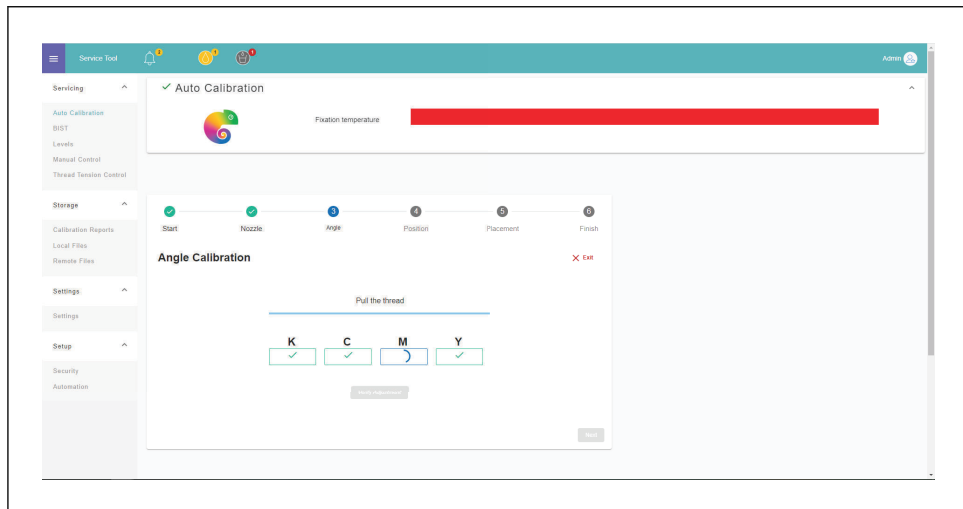

color(s).

2.8.4 To do a Head Position Calibration

1. Select the calibration mode *Head Position Calibration* from the drop down list (B).

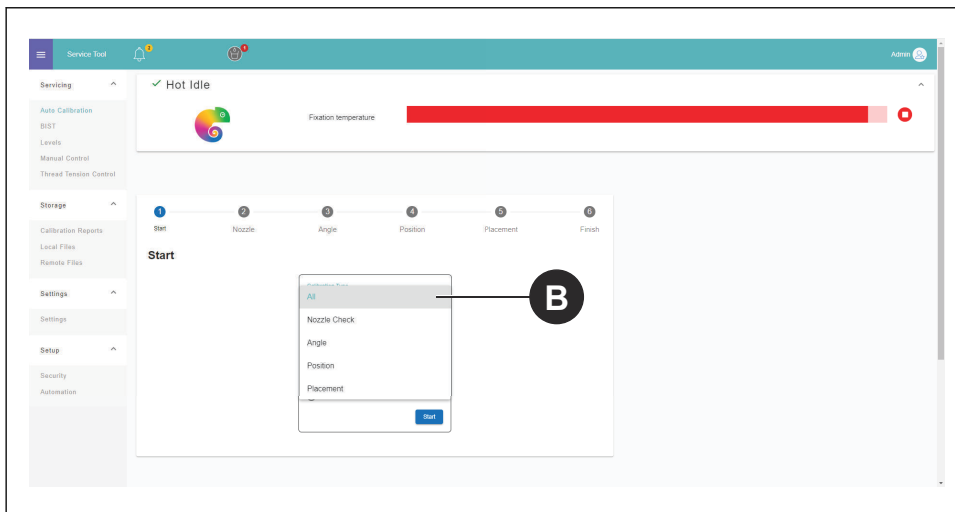

2. Press start.
3. Pull the thread.
4. All colors are calibrated at the same time and the position of each head are saved in the *Config File*.

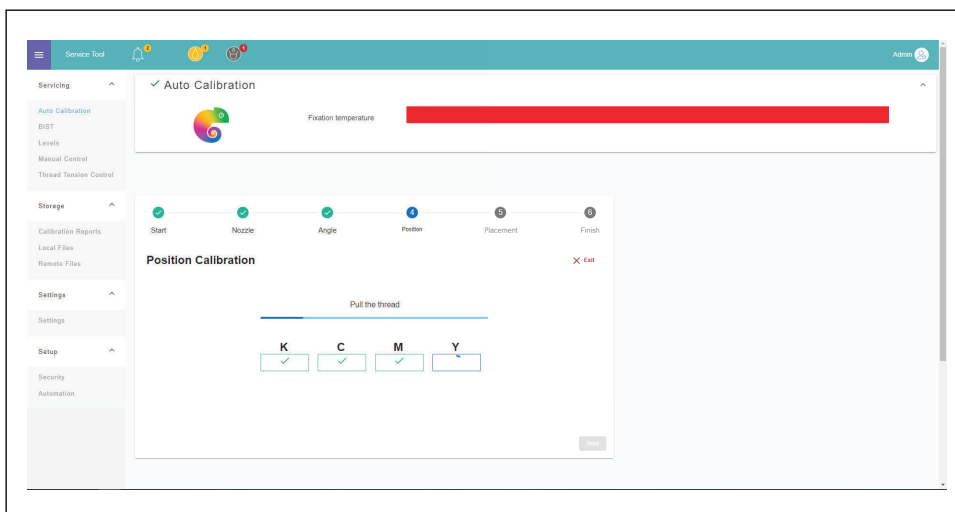

2.8.5 To do a Head Placement Calibration

1. Select the calibration mode *Head Placement Calibration* from the drop down list (B).

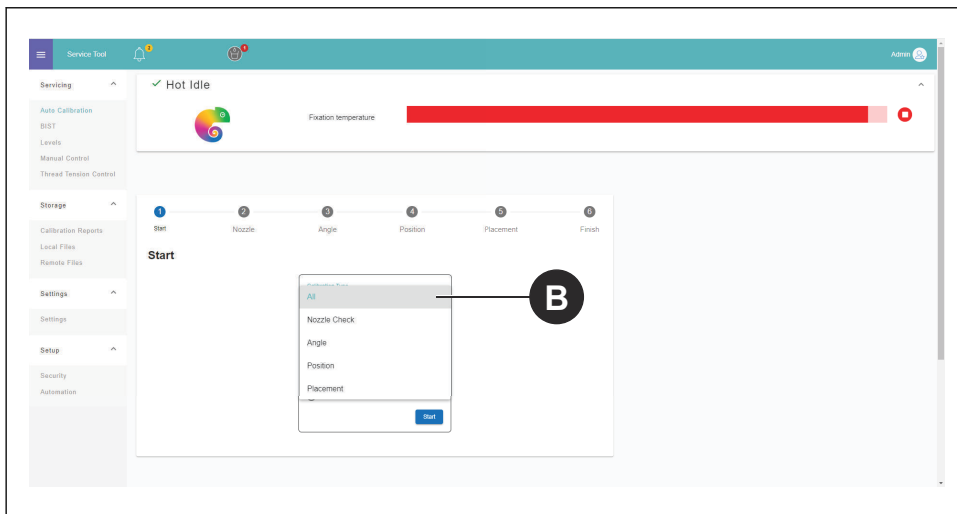

2. Press start.
3. Pull the thread. A pattern of 2 colors is put on the thread.

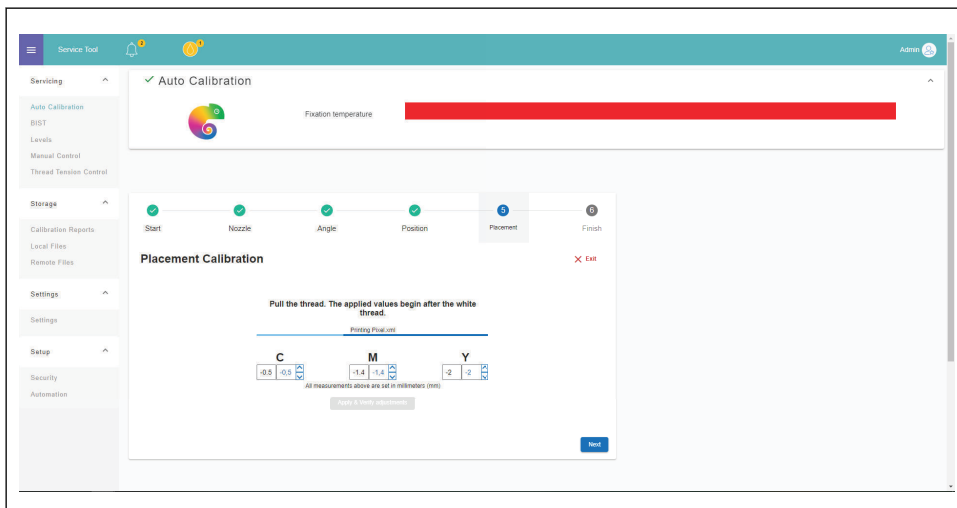

4. Make sure that the colors are put on top of each other, with a maximum deviation gap that is less than 0.2 mm on each side.

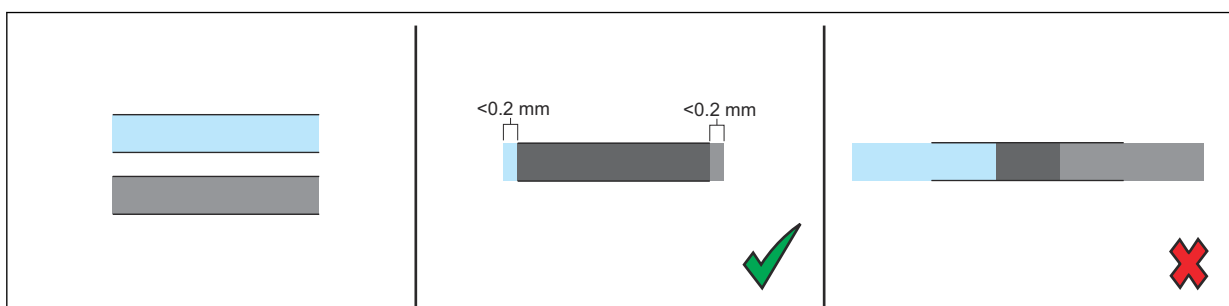

2.8.6 To get the calibration report

1. Select Calibration reports (A) in the side bar menu.

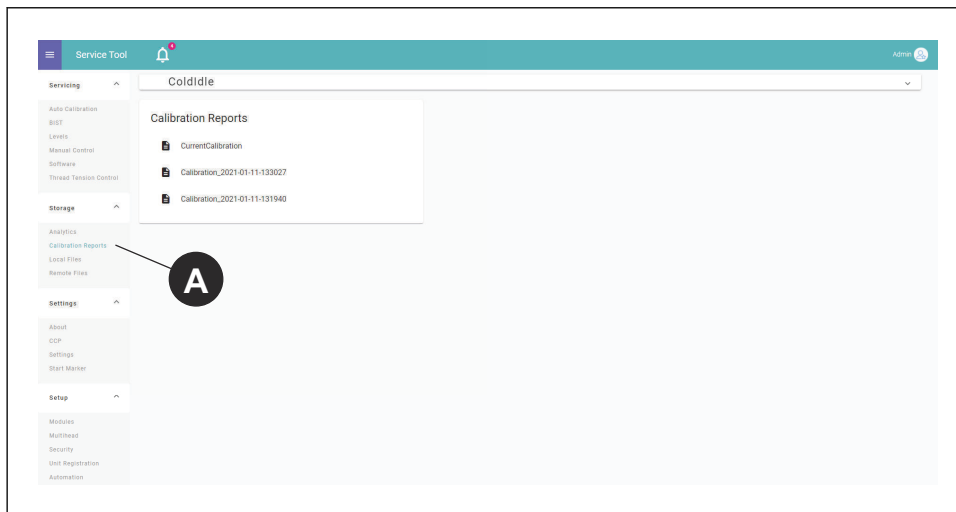

2. Click on the report that you want to show.

2.9 Stitch count settings

To improve Color Change Precision, CCP, you need to add the stitch count information from the embroidery machine. Add the stitch count information in the rows below Embroidery machine in the Color Change Precision, CCP section. Activate advanced stitch count settings for additional parameters. See below for the stitch count information that is required to set the parameters correctly:

For specific embroidery machines, navigate to the support section on .

Standard	
Jump convert	Number of consecutive jump stitches that causes a trim (0-9, default: 3)
Tie ins	Number of tie in stitches (0-10, default: 4)
Tie offs	Number of tie off stitches (0-10, default: 2)
Thread break ties	Number of tie stitches made after a thread break (0-10, default: 0)
The stitch length	Length of a tie stitch in mm (0.1-5, default: 0.5)
Advanced	
Remove DST stitches without any length (default: on)	ON/OFF
Stitch sensor mounted on main shaft	ON/OFF
Additional main shaft rotations during trim	Number of main shaft rotations that occur during trim excluding tie stitches (0-5, default: 1)
Additional main shaft rotations during color change	Number of main shaft rotations that occur during color change excluding tie stitches (0-5, default: 2)

2.9.1 To manage the CCP settings

1. Select *Settings*.
2. Select *Color Change Precision* in the settings menu.

2.9.2 To align the stitch count settings

Refer to the manual of the embroidery machine if you are not sure where to check for the information.

1. Select *Settings*.
2. Select *Color Change Precision* in the settings menu.
3. Add the input data in the fields below *Embroidery machine (A)*.

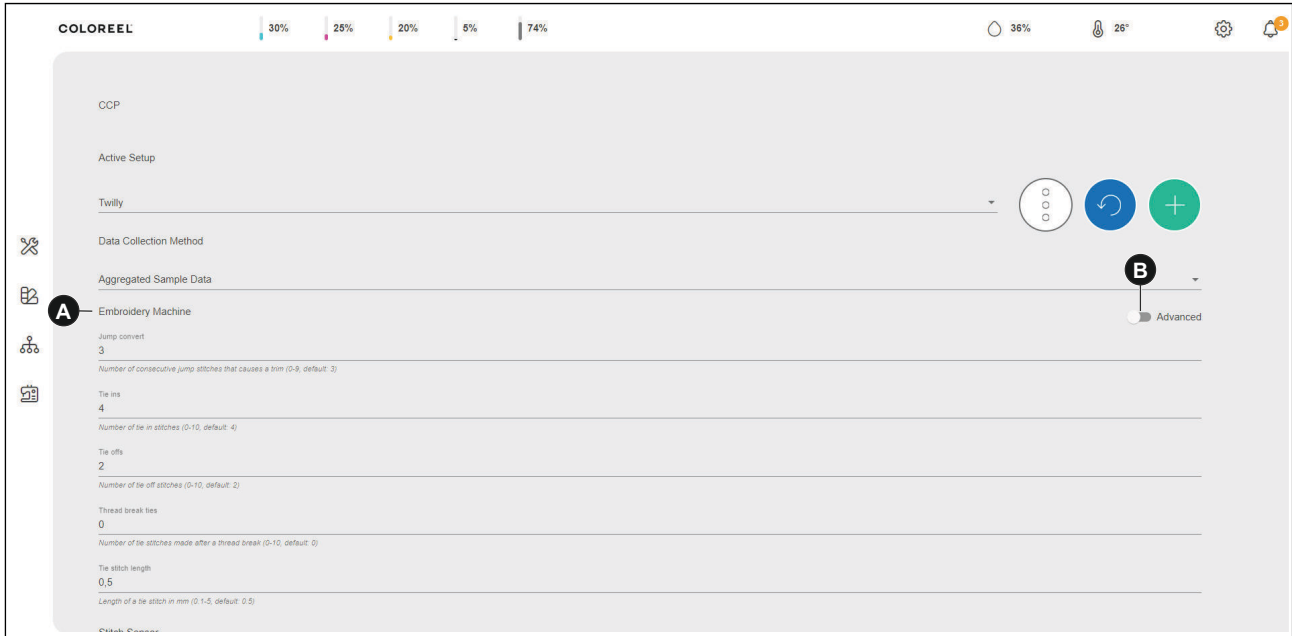

4. To add the advanced settings, select (B) button and add the input data.

Unlock your potential

Coloreel is a Swedish textile innovation brand with groundbreaking technology that enables high-quality coloring of textile thread on demand, unlocking a world of potential.

If you have questions contact us at:

info@coloreel.com

Follow us on the web or social media



Coloreel
Gjuterigatan 9
553 18 Jönköping
Sweden

www.coloreel.com

COLOREEL