

Installation Manual - Non Coloreel Stand

EN

Installation manual

3-20



Contents

1	Safety.....	4			
1.1	Safety definitions.....	4			
1.2	General safety instructions.....	4			
1.3	Safety instructions for installation.....	4			
2	Installation.....	6			
2.1	Introduction.....	6			
2.2	To assemble the Coloreel unit.....	6			
2.3	To attach the product to different installations.....	6			
2.4	Transport Lock.....	10			
2.5	Network Setup.....	10			
2.5.1	To connect a Coloreel ITCU to a network.....	10			
2.5.2	To connect a Coloreel ITCU to a local network.....	11			
2.6	To use the Priming Function.....	12			
2.7	Auto Calibration.....	12			
2.7.1	To access the service tool from the operator panel.....	13			
2.7.2	To do an auto calibration.....	13			
2.7.3	To do a Nozzle check.....	13			
2.7.4	To do a Head Angle Calibration... ..	14			
2.7.5	To do a Head Position Calibration.....	16			
2.7.6	To do a Head Placement Calibration.....	17			
2.7.7	To get the calibration report.....	18			
2.8	Stitch count settings.....	18			
2.8.1	To manage the CCP settings.....	18			
2.8.2	To align the stitch count settings..	19			

1 Safety

1.1 Safety definitions

Warnings, cautions and notes are used to point out especially important parts of the manual.



Warning: Used if there is a risk of injury or death for the operator or bystanders if the instructions in the manual are not followed correctly.



Caution: Used if there is a risk of damage to the product, other materials or the adjacent area if the instructions in the manual are not followed correctly.



Note: Used to give additional information necessary for basic use of the product.

1.2 General safety instructions



Warning: Always read the warning instructions that follow before using the product.

- Read and understand the Operator's Manual, Installation manual and all the instructions on the product carefully before use.
- Do not install, operate or do service and maintenance if you do not fully understand the instructions or how to use the provided parts and products.
- The product creates an electromagnetic field during operation. This field may under some circumstances interfere with active or passive medical implants. To reduce the risk of serious or fatal injury we recommend people with medical implants to consult their physician and the medical implant manufacturer before operating this product.
- The product is approved only with the equipment supplied or recommended by the manufacturer. Failure to use approved equipment can cause damage to the product.
- Electrical shocks can cause injuries. Do not touch the cables when the product is turned on.
- Always follow the instructions provided on the touchscreen.

1.3 Safety instructions for installation



Warning: The service and installation manual shall fulfil the need for installation and service technicians. The receiver of the manual is required to have special training.



Warning: Read the warning instructions that follow before you install the floor stand and the Coloreel unit.

- Always be a minimum of 3 persons during installation. Risk of personal injury.
- The installation procedure described in this manual is recommended by Coloreel for safe operation of the Coloreel unit. Do not install the floor stand or the Coloreel unit in any other way.
- Regularly make sure that the floor stand is stable and that the Coloreel unit is correctly installed to the floor stand. Risk of personal injury or death to the operator.
- High humidity can decrease the lifetime of the floor stand and the Coloreel unit. Perform maintenance and inspections regularly.

- Make sure that the surface where the Coloreel stand and Coloreel ITC Unit are installed on, can withstand the weight of the products used in the installation.
- Make sure that the Coloreel stand is installed correctly and on a dry, horizontal surface.
- For indoor use only.

2 Installation

2.1 Introduction



Warning: Be careful when installing the Coloreel unit. Risk of crush injuries.



Caution: Ensure the Coloreel unit is installed at an angle not deviating more than 3° from the horizontal plane.



Caution: The distance between the Coloreel unit and embroidery needle should be as short as possible for best color precision. The length of the thread between the output and the needle should not exceed 100 cm.



Caution: Install the Coloreel unit so that the angle of the thread between the Coloreel unit and embroidery machine does not deviate more than 10° from the vertical axis.

2.2 To assemble the Coloreel unit

What you need:

Name	Amount
Bolt, M10, minimum grade 8.8	4
Nut, M10	8
Washer, 10.5x20x2, minimum grade 8	8



Note: The Coloreel unit must be installed in a space with a minimum distance of 260 cm between the floor and the roof.

2.3 To attach the product to different installations

1. Remove the detachable doors on the Coloreel unit.

2. Install the bolts (U), the washers (Y) and the nuts (W) to the frame plate of the product.

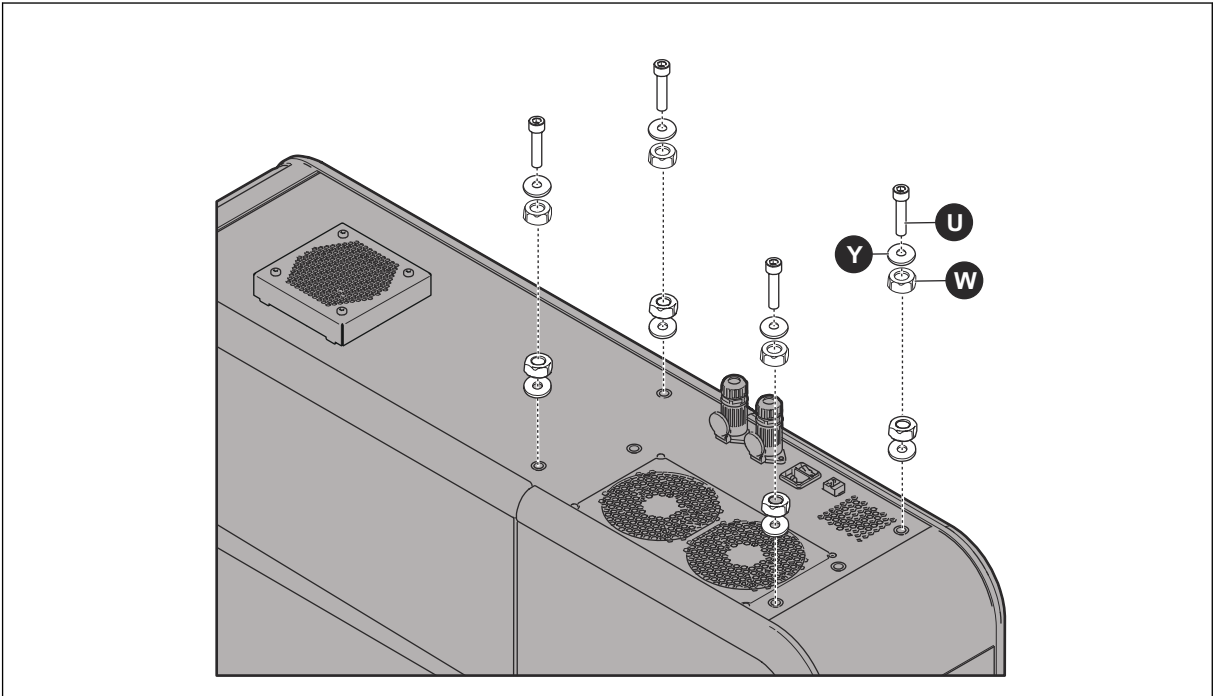

3. Make sure that all bolts are through the holes and can be seen from the inside of the unit.

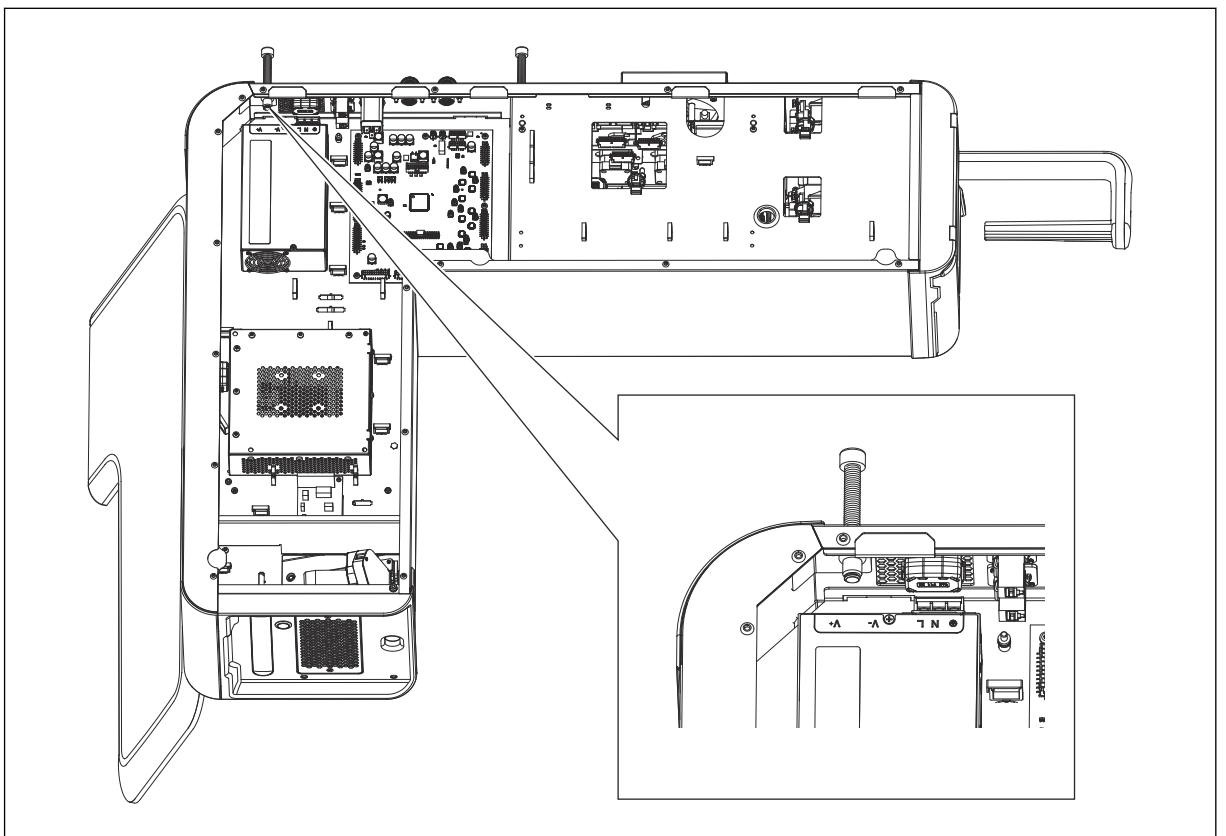
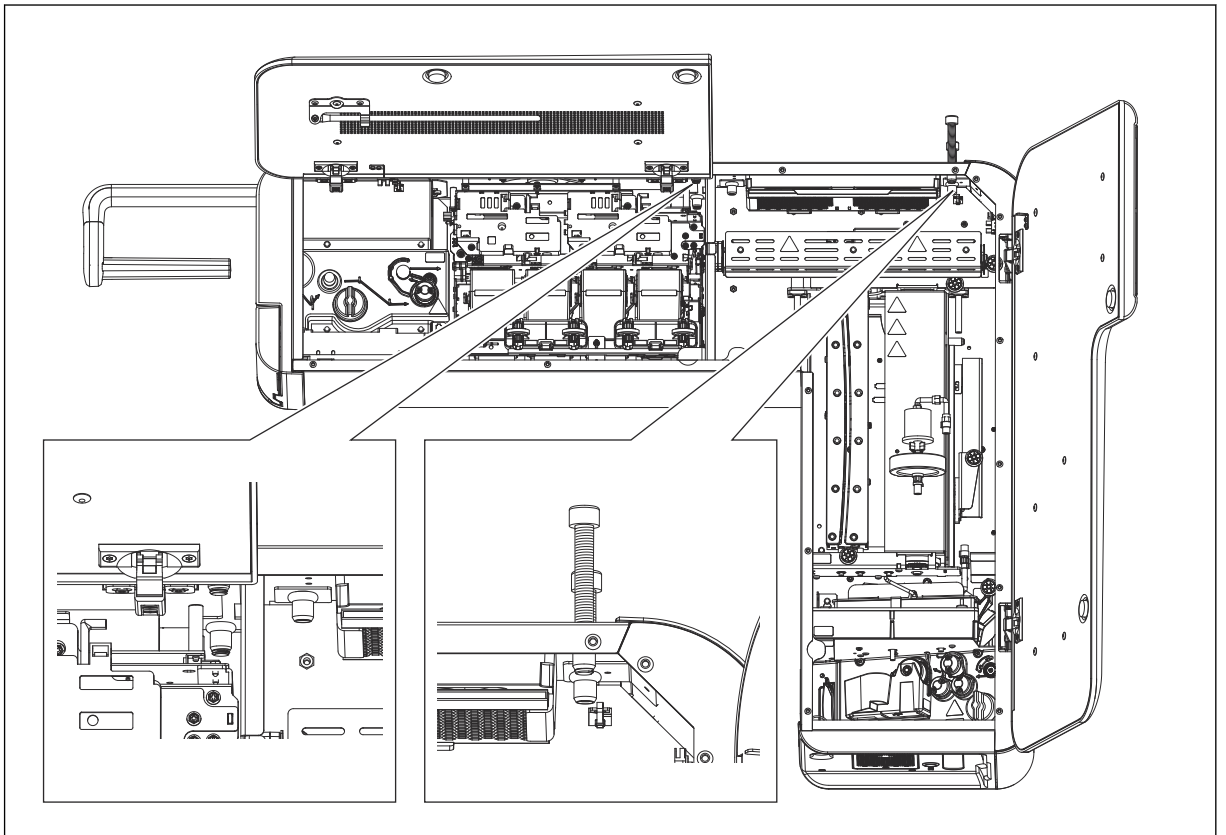

4. If you have an optional lifting equipment, read the instructions for it before use.

- Put a spirit level on top of the product and adjust the bolts to level the Coloreel unit.

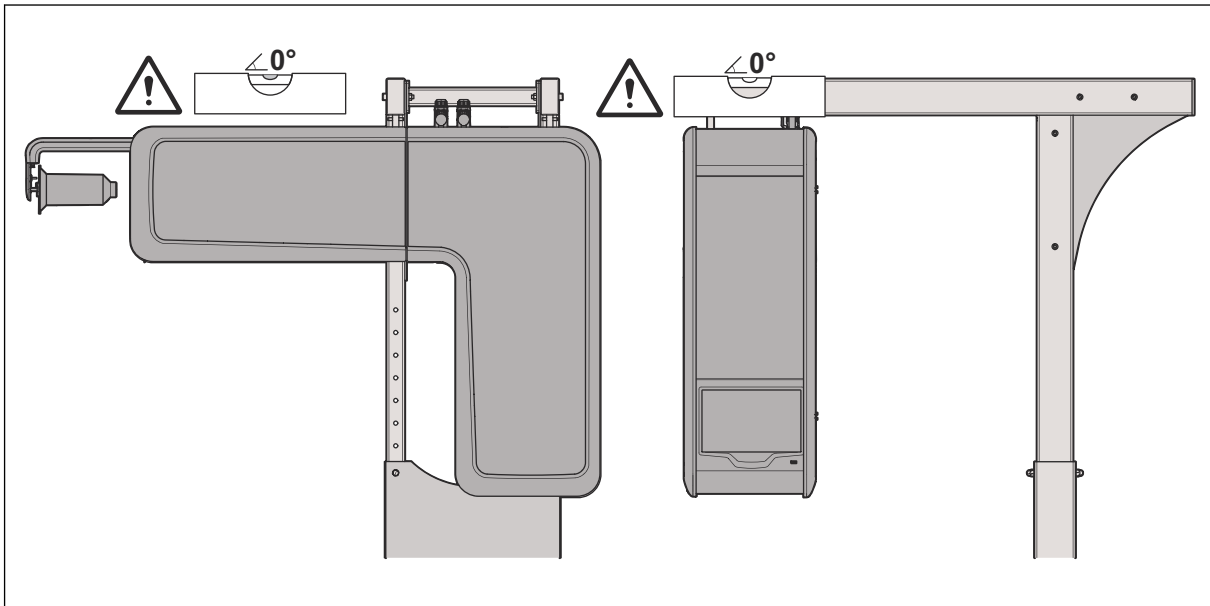

- Place a spirit level on the side of the product and adjust the bolts to level the Coloreel unit.
- Lock and secure the Coloreel unit with the nuts in step 1 above.
- Install the detachable doors on the Coloreel unit and assemble the thread reel.
- Put the embroidery machine in place and make sure that the thread is vertically aligned with the inlet of the thread on the embroidery machine. The angle on the thread should not deviate more than 10° from the vertical line (α) of the ITCU thread outlet (C).

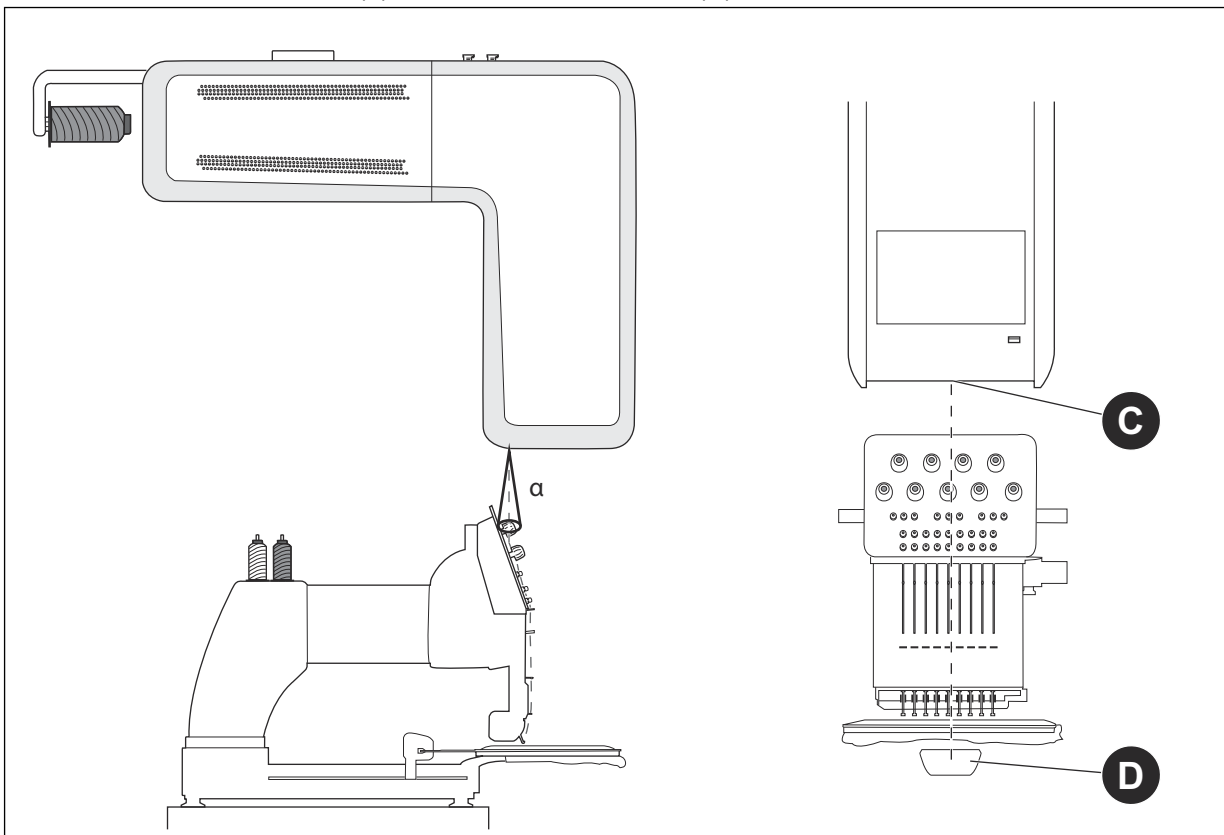

- Make sure that the thread is vertically aligned between the thread outlet (C) and the center of the under thread arm (D).

2.4 Transport Lock



Note: Make sure that you remove all the transport locks (A) before you start the ITCU.

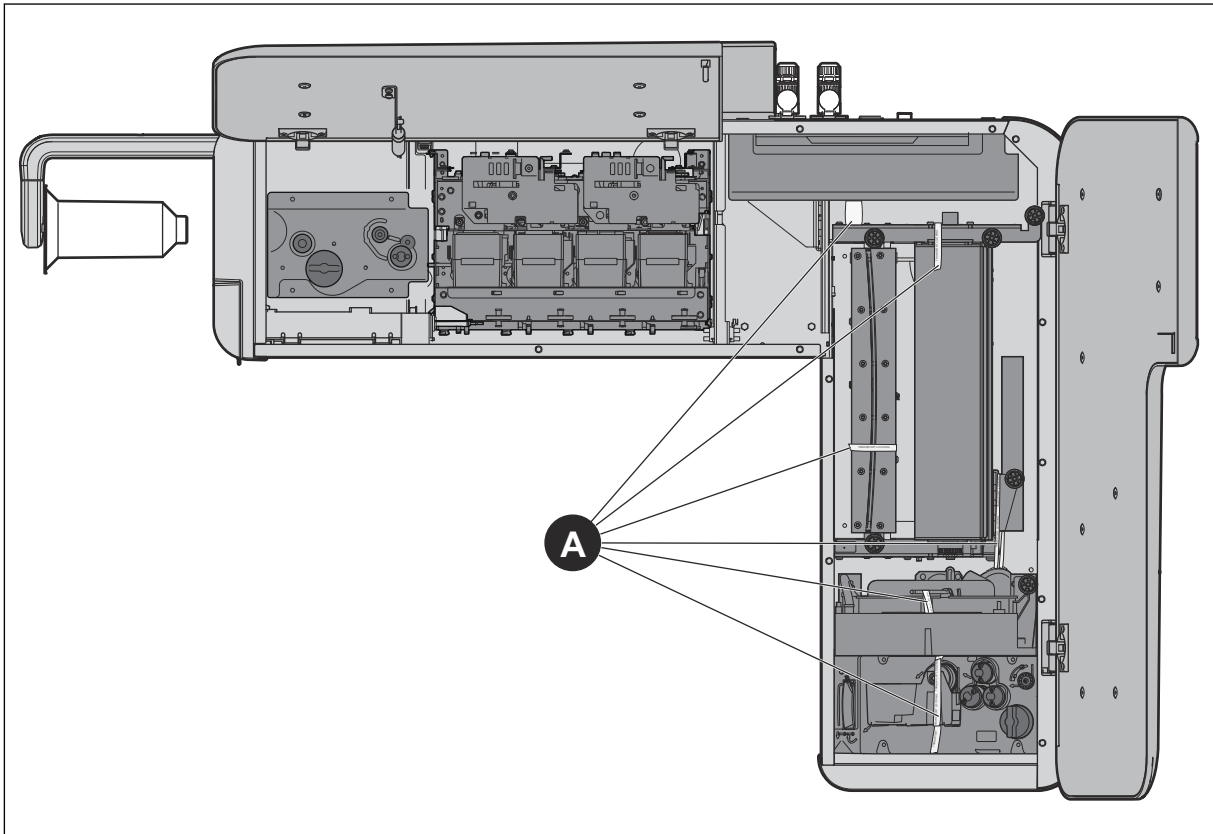

2.5 Network Setup

To use the ITCU, you must install it to a network. We recommend that you install it to an internet connected network to make sure that you get the latest software updates. If that is not possible, you can connect the ITCU through a local network.

2.5.1 To connect a Coloreel ITCU to a network

Make sure that you have a Router (B), access to the internet (C) and a Computer for the Service Tool. The ITCU units will have a separate network inside the company network.

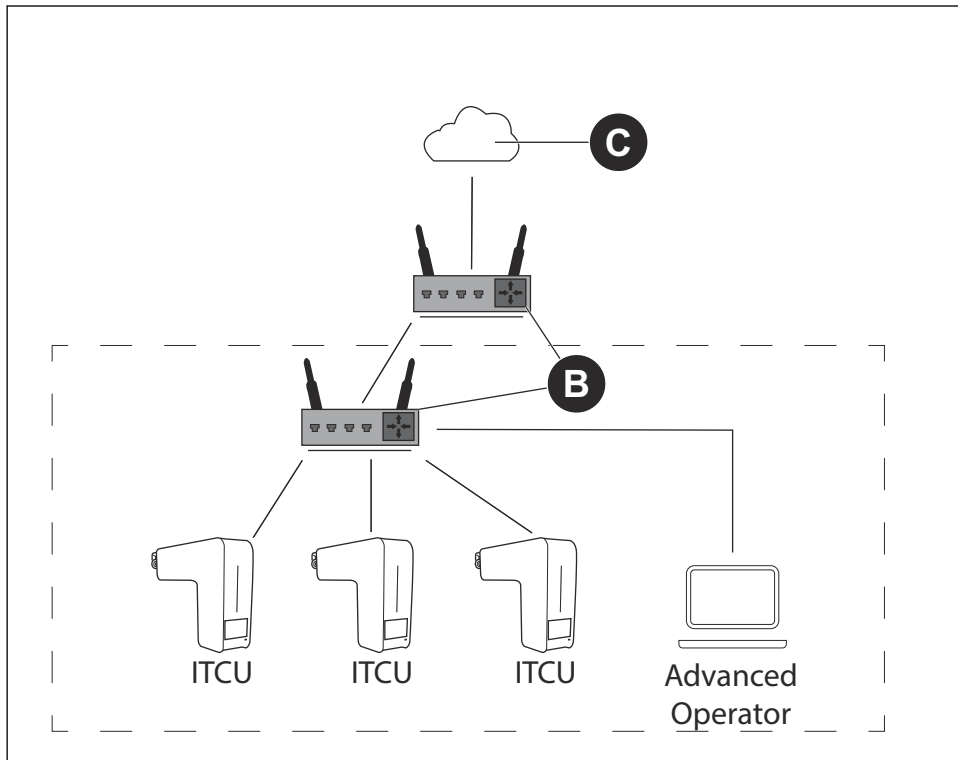

1. Connect the ITCU to the Router (B).
2. Connect the computer to the network with internet access (C).
3. Get the IP address from the ITCU.
4. Log on to the operator panel. You can see the network settings in *Settings>Network*. Refer to the *Full operator manual* for more information.

2.5.2 To connect a Coloreel ITCU to a local network

Make sure that you have a Switch/Router (A) supporting network layer 3 and a Computer for the Advanced Operator access.

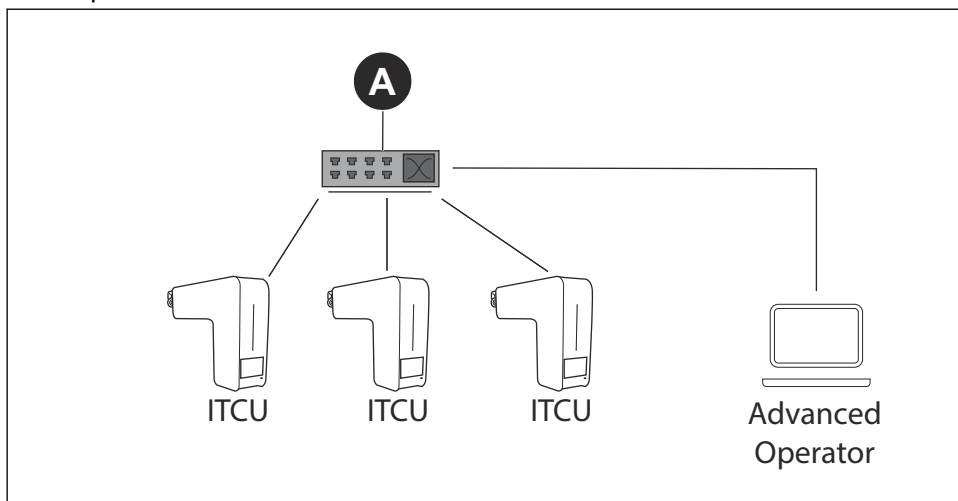

1. Connect the ITCU to the Switch/Router (A).
2. Connect the Computer to the Switch/Router (A).
3. Your Router should use DHCP (ITCU's default configuration) to assign IP Addresses. Get the Coloreel ITCU IP from the screen.
4. Log on to the operator panel. You can see the network settings in *Settings>Network*. Refer to the *Full operator manual* for more information.

2.6 To use the Priming Function

The Priming Function must be used before operating the Coloreel unit for the first time.

1. Ensure that all the color cartridges are installed before starting the Coloreel unit.
2. Make sure that the Waste Tank is empty.
3. In the operator panel, select *Maintenance*.

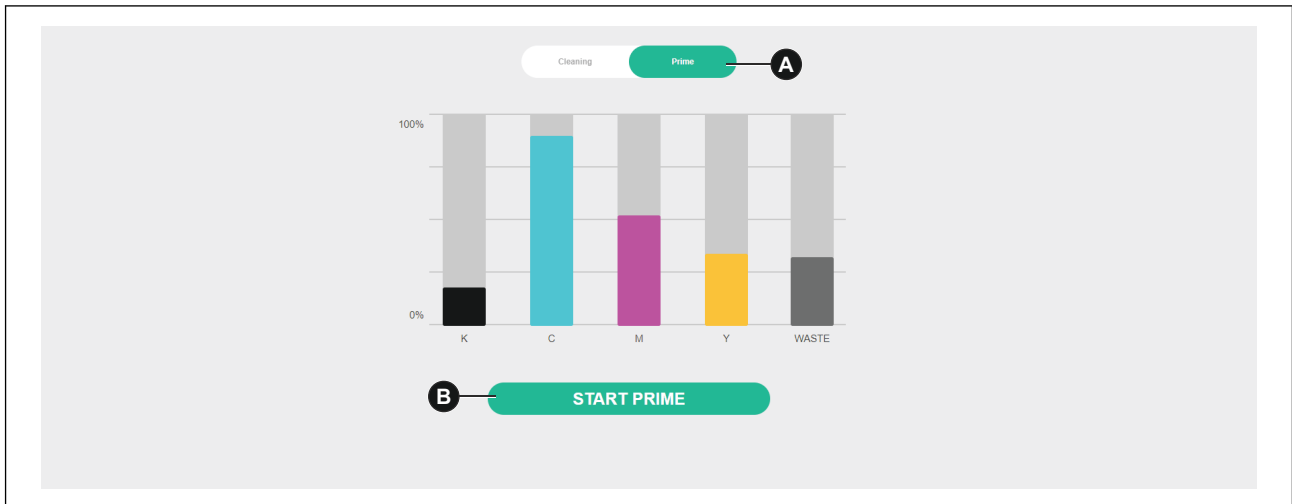

4. Select *Prime* (A).
5. Click on the *Start prime* button (B).
6. Click in the *Confirm* button (C). The prime procedure starts.

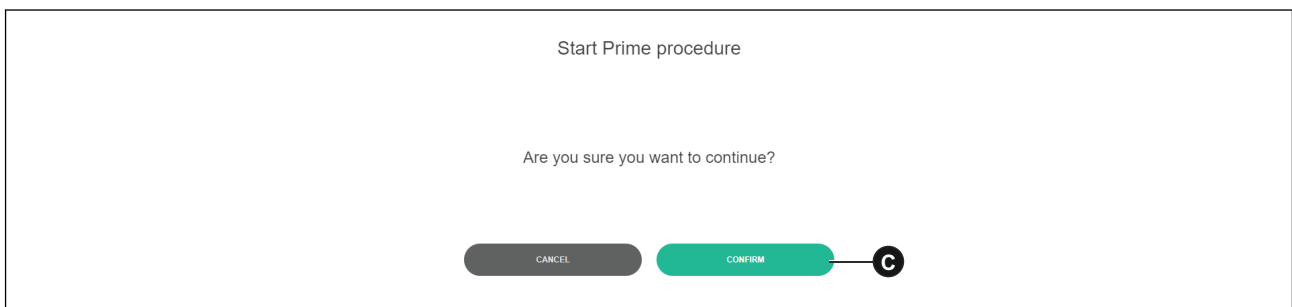

2.7 Auto Calibration

On the Auto Calibration Card (A), it is possible to calibrate print heads so that ink is correctly applied to the thread.

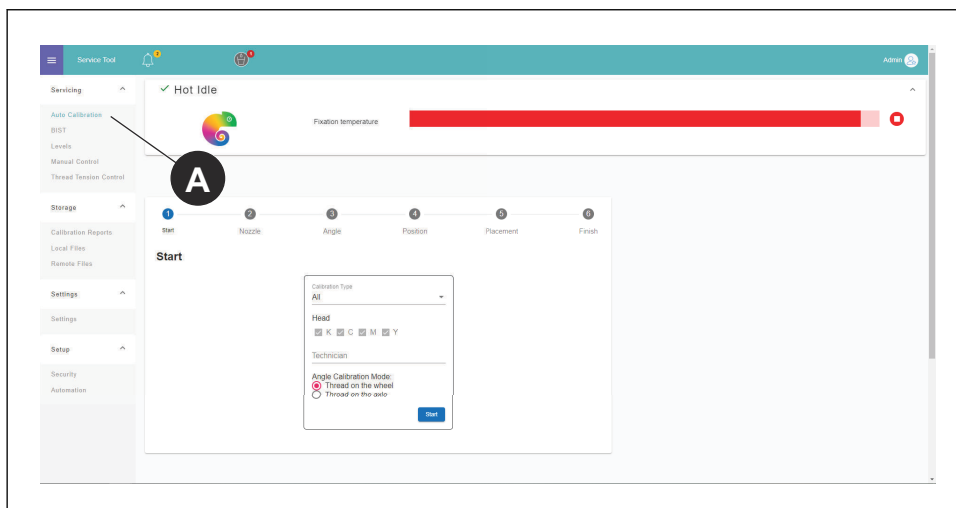

2.7.1 To access the service tool from the operator panel

1. Select *Settings*.
2. Select *Service tool* in the settings menu. You are rerouted to the service tool.

2.7.2 To do an auto calibration

The auto calibration can be done in different ways. The *All* calibration mode will calibrate all colors. Other calibration modes can do calibrations for 1 color separately.

1. Select the calibration mode *All* from the drop down list (B).

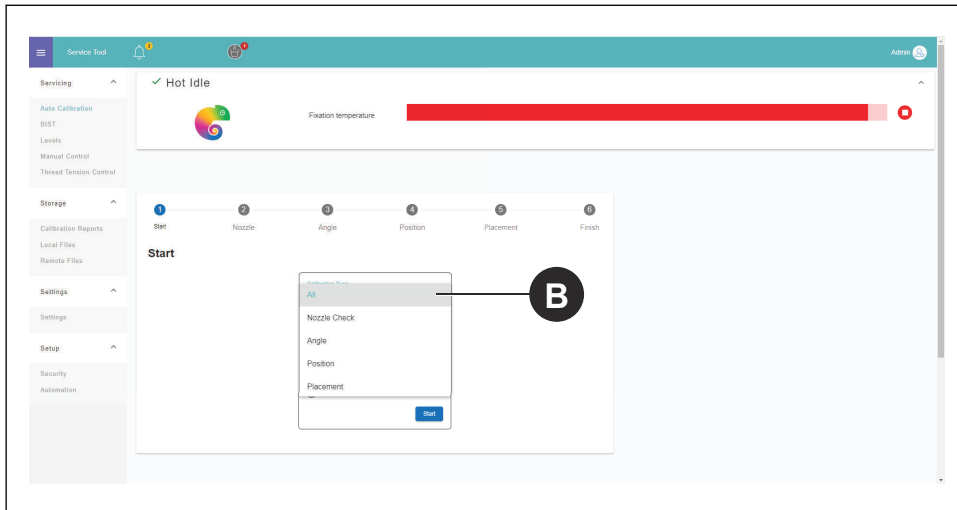

2. Press start and let the auto calibration finish.



Note: The ITCU enters *Service Mode* and warm up, when you start the auto calibration.

2.7.3 To do a Nozzle check

1. Select the calibration mode *Nozzle check* from the drop down list (B).

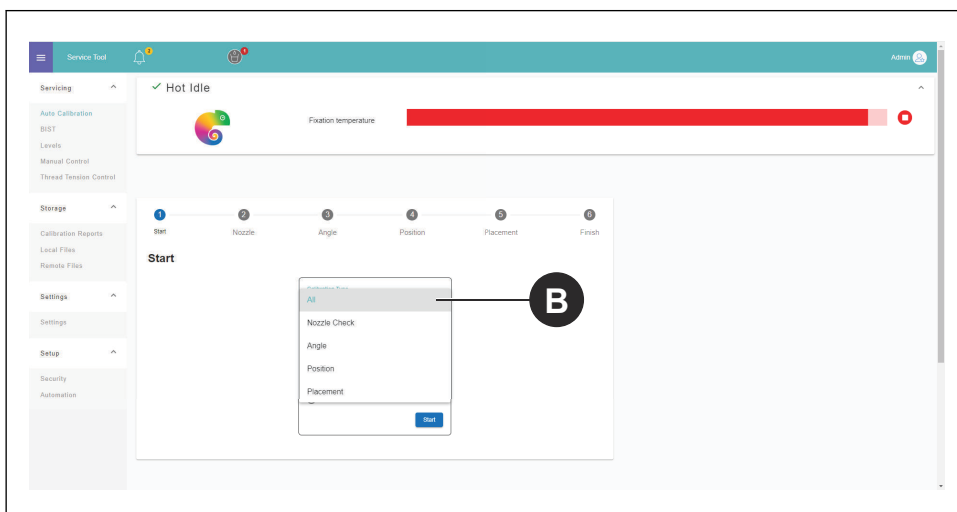

2. Press start.
3. Hold a piece of paper between the thread and the nozzle head.
4. Pull the paper against you and at the same time, pull the thread in the direction of the thread feed.

5. Make sure that there is color on each section.

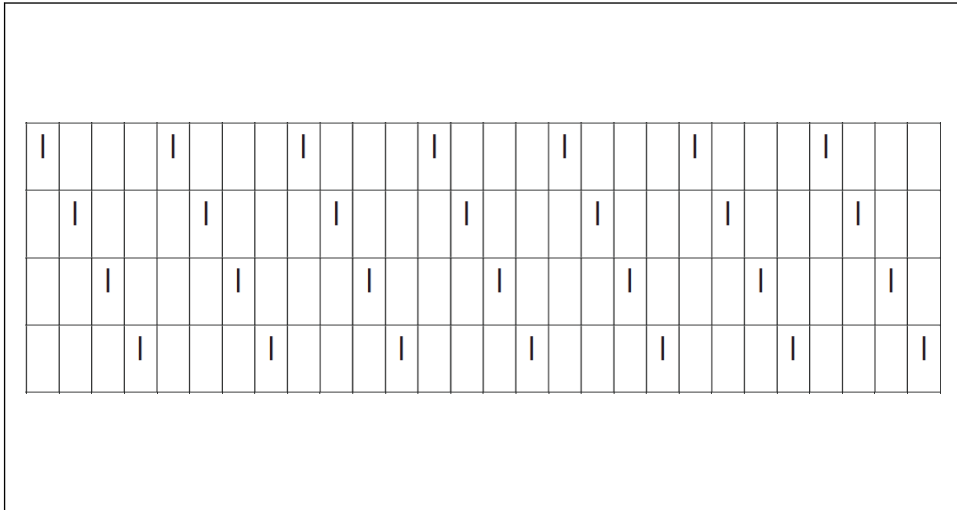

2.7.4 To do a Head Angle Calibration

1. Select the calibration mode *Head Angle Calibration* from the drop down list (B).

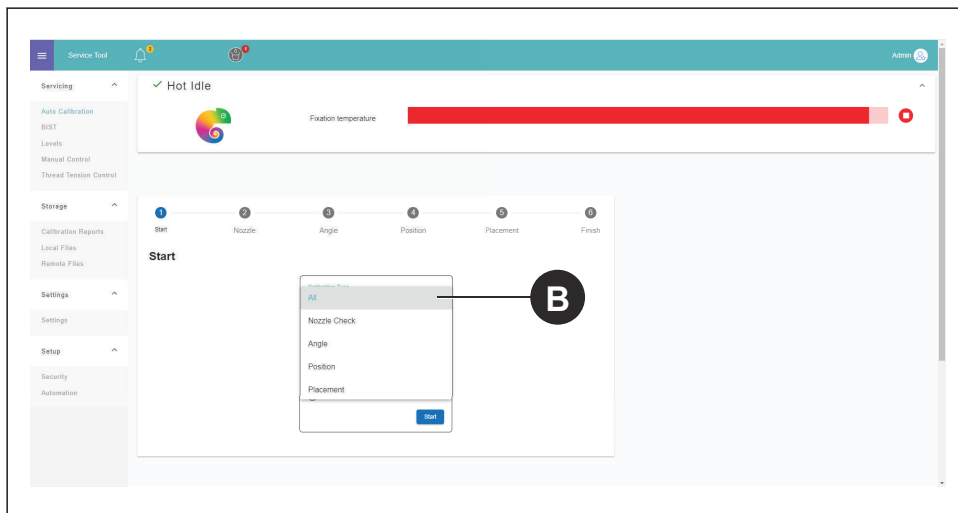

2. Pull the

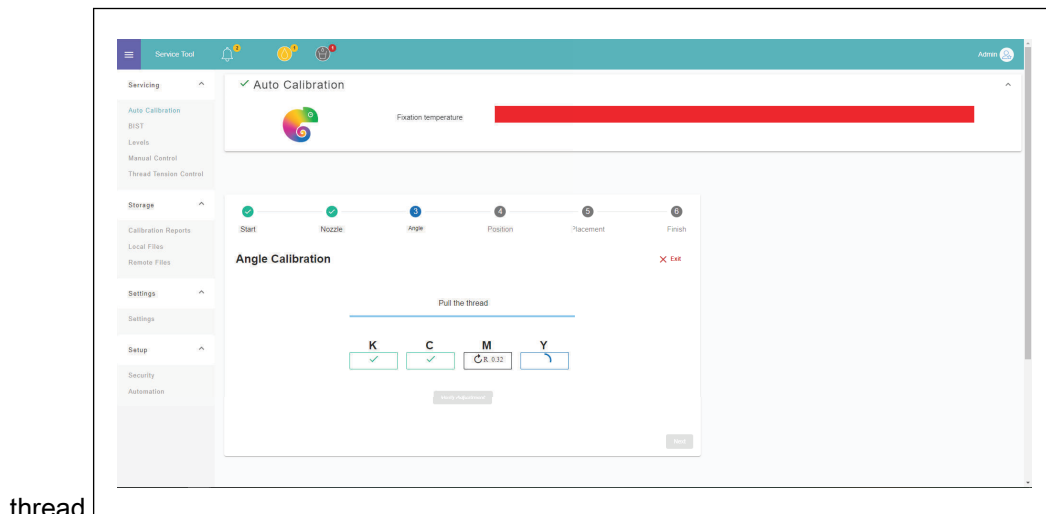

thread.

3. If an adjustment is needed, press *start*

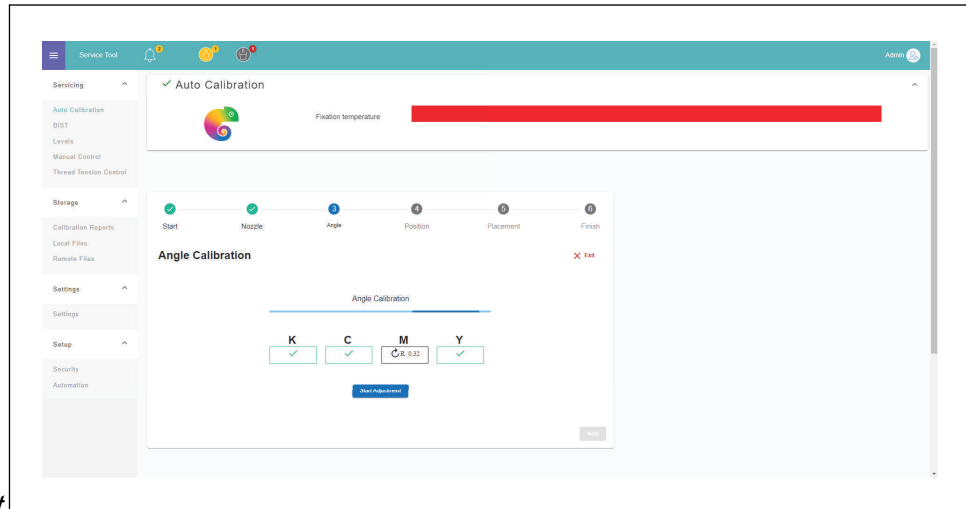

adjustment.

4. Adjust the colors that shows a deviation on the screen.

5. Press *Cap current head* when the adjustments are

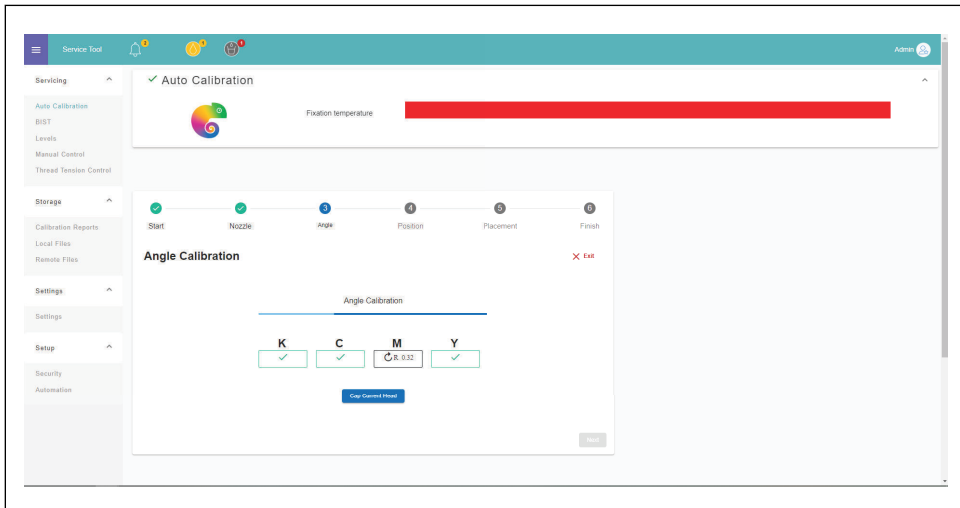

done.

6. Press *verify adjustment* and pull the thread to do a calibration of the adjusted

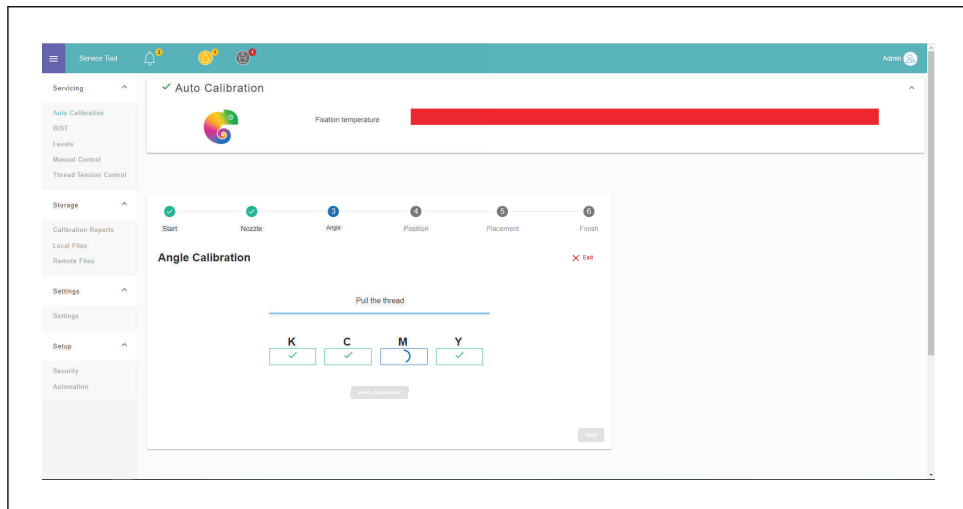

color(s).

2.7.5 To do a Head Position Calibration

1. Select the calibration mode *Head Position Calibration* from the drop down list (B).

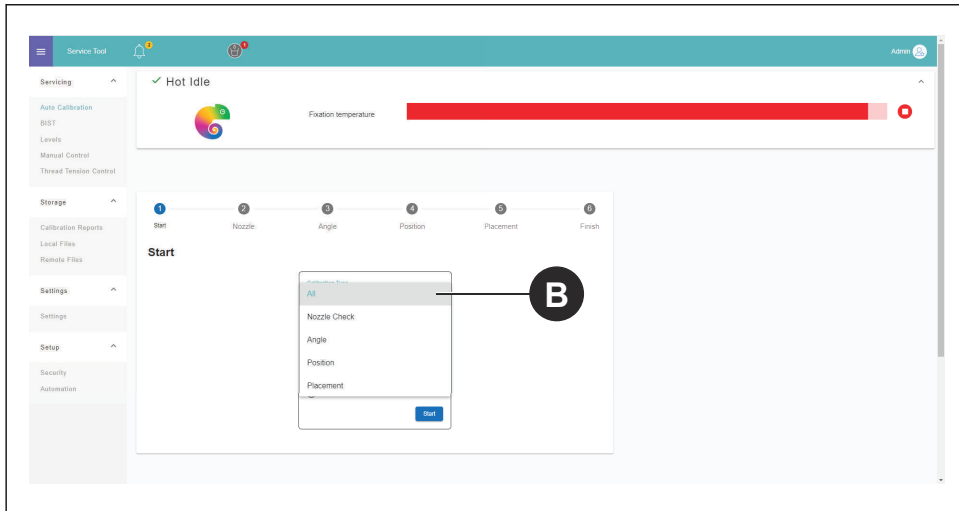

2. Press start.
3. Pull the thread.
4. All colors are calibrated at the same time and the position of each head are saved in the *Config File*.

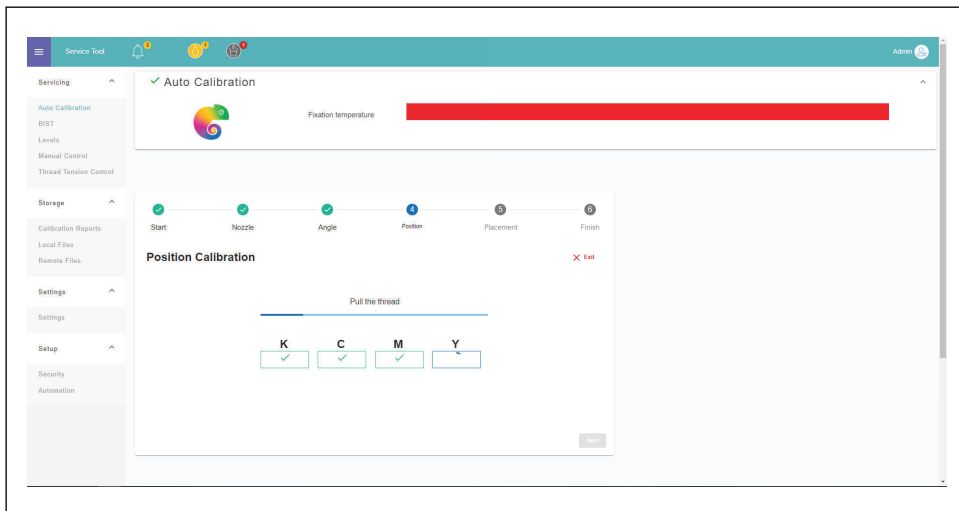

2.7.6 To do a Head Placement Calibration

1. Select the calibration mode *Head Placement Calibration* from the drop down list (B).

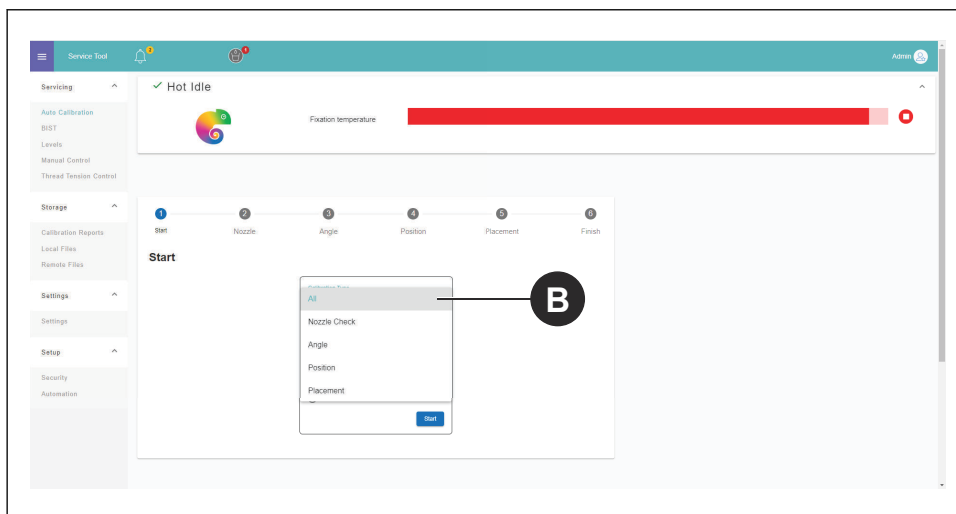

2. Press start.
3. Pull the thread. A pattern of 2 colors is put on the thread.

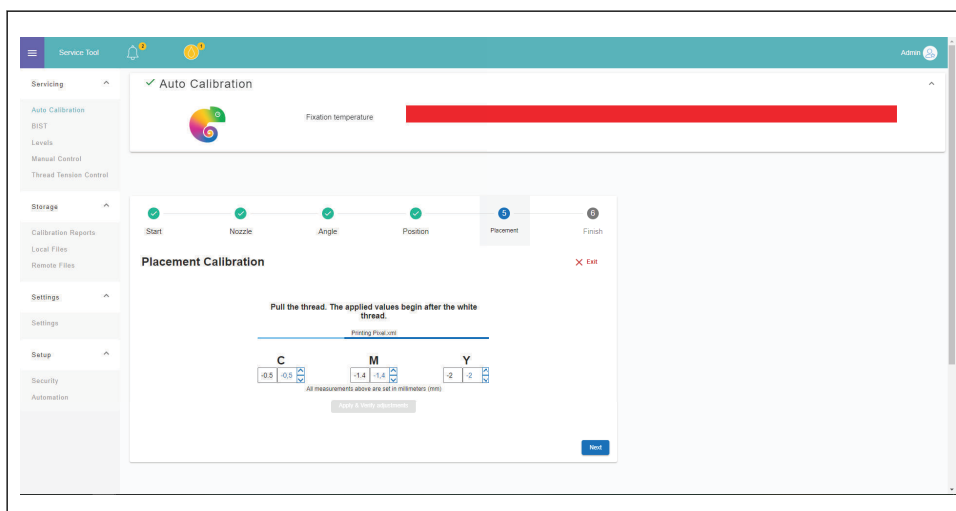

4. Make sure that the colors are put on top of each other, with a maximum deviation gap that is less than 0.2 mm on each side.

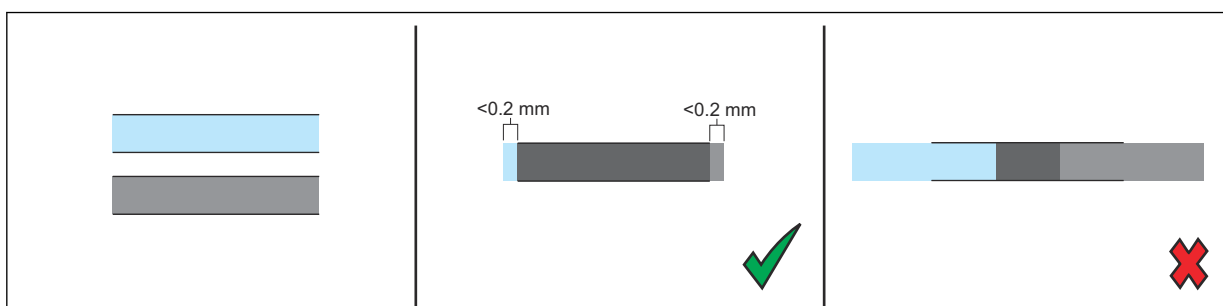

2.7.7 To get the calibration report

1. Select Calibration reports (A) in the side bar menu.

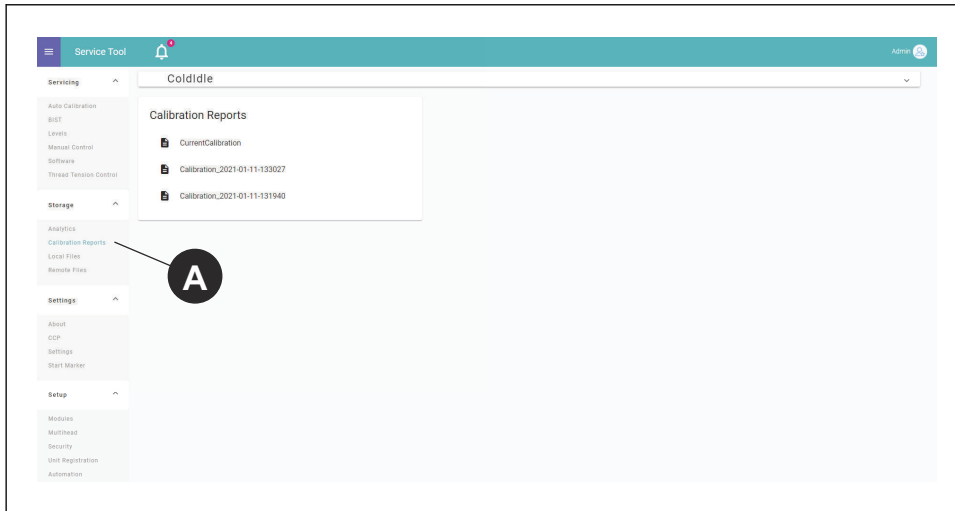

2. Click on the report that you want to show.

2.8 Stitch count settings

To improve Color Change Precision, CCP, you need to add the stitch count information from the embroidery machine. Add the stitch count information in the rows below Embroidery machine in the Color Change Precision, CCP section. Activate advanced stitch count settings for additional parameters. See below for the stitch count information that is required to set the parameters correctly:

For specific embroidery machines, navigate to the support section on .

Standard	
Jump convert	Number of consecutive jump stitches that causes a trim (0-9, default: 3)
Tie ins	Number of tie in stitches (0-10, default: 4)
Tie offs	Number of tie off stitches (0-10, default: 2)
Thread break ties	Number of tie stitches made after a thread break (0-10, default: 0)
The stitch length	Length of a tie stitch in mm (0.1-5, default: 0.5)
Advanced	
Remove DST stitches without any length (default: on)	ON/OFF
Stitch sensor mounted on main shaft	ON/OFF
Additional main shaft rotations during trim	Number of main shaft rotations that occur during trim excluding tie stitches (0-5, default: 1)
Additional main shaft rotations during color change	Number of main shaft rotations that occur during color change excluding tie stitches (0-5, default: 2)

2.8.1 To manage the CCP settings

1. Select *Settings*.
2. Select *Color Change Precision* in the settings menu.

2.8.2 To align the stitch count settings

Refer to the manual of the embroidery machine if you are not sure where to check for the information.

1. Select *Settings*.
2. Select *Color Change Precision* in the settings menu.
3. Add the input data in the fields below *Embroidery machine (A)*.

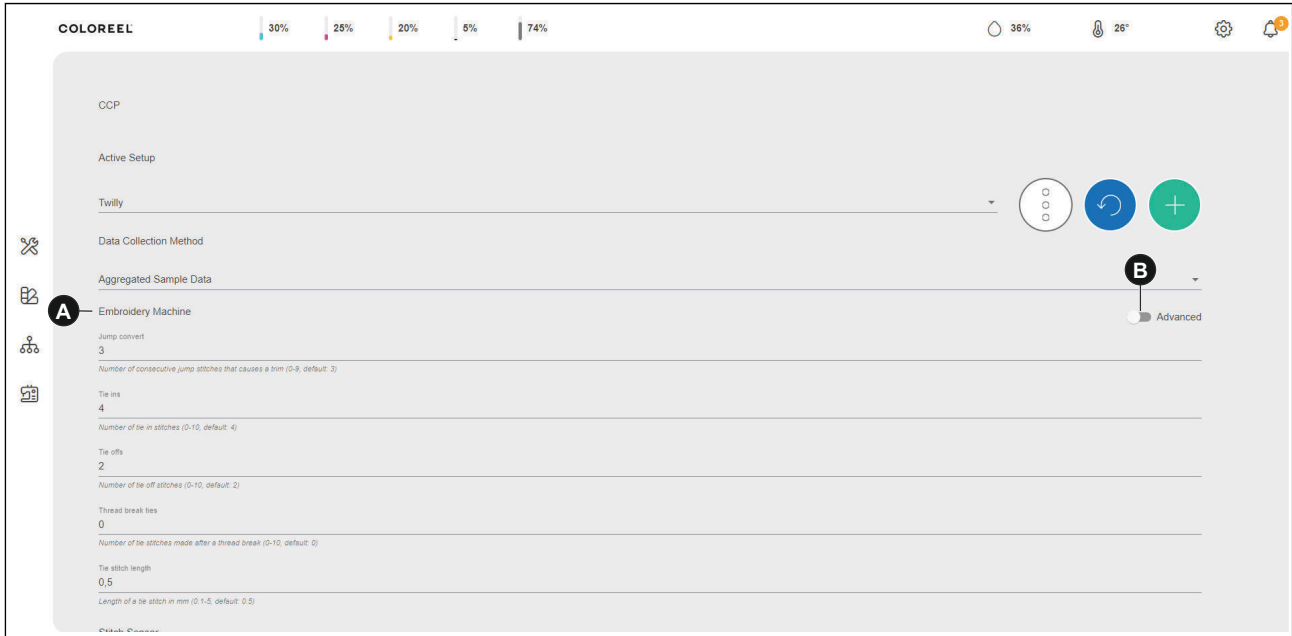

4. To add the advanced settings, select (B) button and add the input data.

Unlock your potential

Coloreel is a Swedish textile innovation brand with groundbreaking technology that enables high-quality coloring of textile thread on demand, unlocking a world of potential.

If you have questions contact us at:

info@coloreel.com

Follow us on the web or social media



Coloreel
Gjuterigatan 9
553 18 Jönköping
Sweden

www.coloreel.com

COLOREEL